



## Manual

### Digital Display WAY-SX

#### Product features:

- Master or Slave operation with clock frequencies up to 1 MHz
- For single turn and multi turn encoders with SSI formats from 10 ... 32 Bit
- Bright and high-contrast display with event-dependent color variations
- Emulation of a 7-segment display inclusively icons and units
- Intuitive and easy parameterization by plain text and touchscreen
- 5 V / 24 V auxiliary output for encoder supply
- Linearization with 24 control points
- Numerous features, e. g. scaling, bit blanking etc.
- 3.78 x 1.89 inch norm panel housing and IP65 protection

#### Available options:

**WAY-SX:** Basic unit with SSI interface, 3 control inputs, 5 / 24 VDC encoder supply

- Option **AC:** Power supply 115 / 230 VAC
- Option **AO:** 16 bit analog output, 4 control outputs, serial RS232 interface
- Option **AR:** 16 bit analog output, 4 control outputs, serial RS485 interface
- Option **CO:** 4 control outputs, serial RS232 interface
- Option **CR:** 4 control outputs, serial RS485 interface
- Option **RL:** 2 relay outputs

**Options can be combined**

**Legal notices:**

All contents included in this manual are protected by the terms of use and copyrights of WayCon GmbH. Any reproduction, modification, usage or publication in other electronic and printed media as well as in the internet requires prior written authorization by WayCon GmbH.

# Table of content

<b>1. Safety Instructions and Responsibility.....</b>	<b>5</b>
1.1. General Safety Instructions.....	5
1.2. Use according to the intended purpose .....	5
1.3. Installation.....	6
1.4. EMC Guidelines.....	6
1.5. Cleaning, Maintenance and Service Notes.....	6
<b>2. Introduction .....</b>	<b>7</b>
2.1. Operation mode.....	7
2.2. Function diagram .....	7
<b>3. Electrical Connections.....</b>	<b>8</b>
3.1. DC Power Supply .....	8
3.2. Auxiliary Voltage Output.....	8
3.3. SSI-Inputs.....	9
3.4. Control Inputs .....	10
3.5. Analog Output (Option AO/AR) .....	10
3.6. Serial interface (Option AO/AR/CO/CR).....	11
3.7. Control-Output (Option AO/AR/CO/CR) .....	11
3.8. AC Power supply (Option AC).....	12
3.9. Relay-Output (Option RL).....	12
<b>4. Display and touch screen.....</b>	<b>13</b>
4.1. Screen structure for parametrization.....	13
4.2. Screen structure in operation .....	14
4.3. Error Message.....	16
<b>5. Parameter / Overview-Menu Structure .....</b>	<b>18</b>
5.1. General Menu.....	20
5.2. SSI Properties.....	21
5.3. Position Settings .....	23
5.4. Speed Settings .....	26
5.5. Preselection Values .....	27
5.6. Preselection 1 Menu .....	28
5.7. Preselection 2 Menu .....	31
5.8. Preselection 3 Menu .....	32
5.9. Preselection 4 Menu .....	33
5.10. Serial Menu .....	34
5.11. Analog Menu.....	36
5.12. Command Menu .....	37
5.13. Display Menu.....	39
5.14. Linearization Menu.....	41
<b>6. Appendix .....</b>	<b>42</b>
6.1. Data readout via serial interface .....	42
6.2. Modbus RTU Interface.....	43
6.2.1. Parameter setting.....	43
6.2.2. Modbus Communication .....	44
6.2.3. Diagnose.....	46
6.3. Parameter / serial codes .....	46

6.4. Linearization .....	50
6.5. Reading SSI-Value .....	52
6.6. Internal processing and calculation of SSI data.....	53
6.7. Dimensions .....	56
6.8. Technical Specifications: .....	57

# 1. Safety Instructions and Responsibility

## 1.1. General Safety Instructions

This operation manual is a significant component of the unit and includes important rules and hints about the installation, function and usage. Non-observance can result in damage and/or impairment of the functions to the unit or the machine or even in injury to persons using the equipment!

**Please read the following instructions carefully before operating the device and observe all safety and warning instructions! Keep the manual for later use.**

A pertinent qualification of the respective staff is a fundamental requirement in order to use this manual. The unit must be installed, connected and put into operation by a qualified electrician.

**Liability exclusion:** The manufacturer is not liable for personal injury and/or damage to property and for consequential damage, due to incorrect handling, installation and operation. Further claims, due to errors in the operation manual as well as misinterpretations are excluded from liability.

In addition, the manufacturer reserves the right to modify the hardware, software or operation manual at any time and without prior notice. Therefore, there might be minor differences between the unit and the descriptions in operation manual.

The raiser respectively positioner is exclusively responsible for the safety of the system and equipment where the unit will be integrated.

During installation or maintenance all general and also all country- and application-specific safety rules and standards must be observed.

If the device is used in processes, where a failure or faulty operation could damage the system or injure persons, appropriate precautions to avoid such consequences must be taken.

## 1.2. Use according to the intended purpose

The unit is intended exclusively for use in industrial machines, constructions and systems. Non-conforming usage does not correspond to the provisions and lies within the sole responsibility of the user. The manufacturer is not liable for damages which have arisen through unsuitable and improper use.

Please note that device may only be installed in proper form and used in a technically perfect condition (in accordance to the Technical Specifications). The device is not suitable for operation in explosion-proof areas or areas which are excluded by the EN 61010-1 standard.

## 1.3. Installation

The device is only allowed to be installed and operated within the permissible temperature range. Please ensure an adequate ventilation and avoid all direct contact between the device and hot or aggressive gases and liquids.

Before installation or maintenance, the unit must be disconnected from all voltage-sources. Further it must be ensured that no danger can arise by touching the disconnected voltage-sources.

Devices which are supplied by AC-voltages must be connected exclusively by switches, respectively circuit-breakers with the low voltage network. The switch or circuit-breaker must be placed as near as possible to the device and further indicated as separator.

Incoming as well as outgoing wires and wires for extra low voltages (ELV) must be separated from dangerous electrical cables (SELV circuits) by using a double resp. increased isolation.

All selected wires and isolations must be conformed to the provided voltage- and temperature-ranges. Further all country- and application-specific standards, which are relevant for structure, form and quality of the wires, must be ensured. Indications about the permissible wire cross-sections for wiring are described in the Technical Specifications.

Before first start-up it must be ensured that all connections and wires are firmly seated and secured in the screw terminals. All (inclusively unused) terminals must be fastened by turning the relevant screws clockwise up to the stop.

Overvoltage at the connections must be limited to values in accordance to the overvoltage category II.

## 1.4. EMC Guidelines

All WayCon devices are designed to provide high protection against electromagnetic interference. Nevertheless, you must minimize the influence of electromagnetic noise to the device and all connected cables.

Therefore, the following measures are mandatory for a successful installation and operation:

- **Use shielded cables for all signal and control input and output lines.**
- **Cables for digital controls (digital I/O, relay outputs) must not exceed a length of 30 m and are allowed for in building operation only**
- Use shield connection clamps to connect the cable shields properly to earth
- The wiring of the common ground lines must be star-shaped and common ground must be connected to earth at only one single point
- The device should be mounted in a metal enclosure with sufficient distance to sources of electromagnetic noise.
- Run signal and control cables apart from power lines and other cables emitting electromagnetic noise.

## 1.5. Cleaning, Maintenance and Service Notes

To clean the front of the unit please use only a slightly damp (not wet!), soft cloth. For the rear no cleaning is necessary. For an unscheduled, individual cleaning of the rear the maintenance staff or assembler is self-responsible.

During normal operation no maintenance is necessary. In case of unexpected problems, failures or malfunctions the device must be shipped for back to the manufacturer for checking, adjustment and reparation (if necessary). Unauthorized opening and repairing can have negative effects or failures to the protection-measures of the unit.

## 2. Introduction

The SSI display device is designed for panel mounting. It is universally applicable, with its intuitive operation, the extensive features and options.

### 2.1. Operation mode

All functions are can be configured in the parameter menu.

The device can be set to one of the following operation modes:

- MASTER
  - The clock for the connected sensor is produced.
  - Both clock terminals (CLK, / CLK) are configured as outputs in this case.
- SLAVE
  - The clock for the encoder is generated by an external device (the SSI master).
  - Both clock terminals (CLK, / CLK) are configured as inputs in this case.

### 2.2. Function diagram

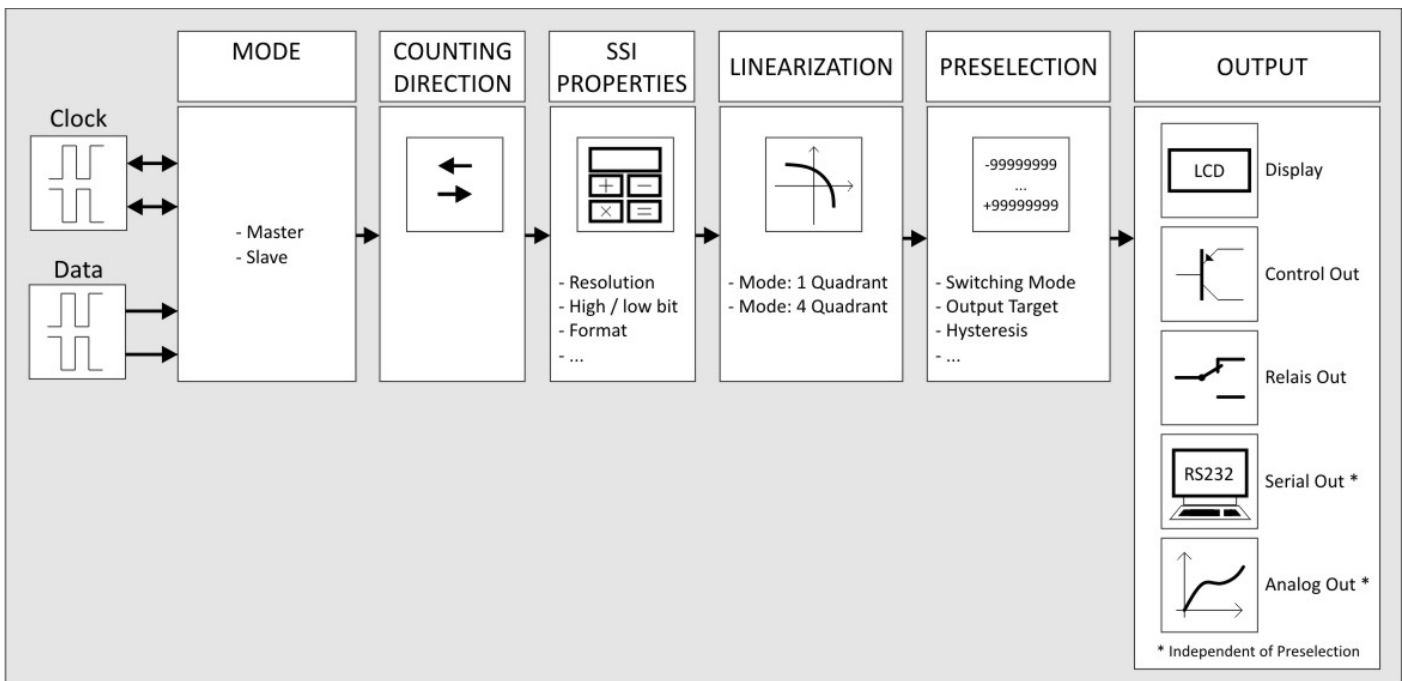

### 3. Electrical Connections

The terminal screws should be tightened with a slotted screwdriver (blade width 2mm).

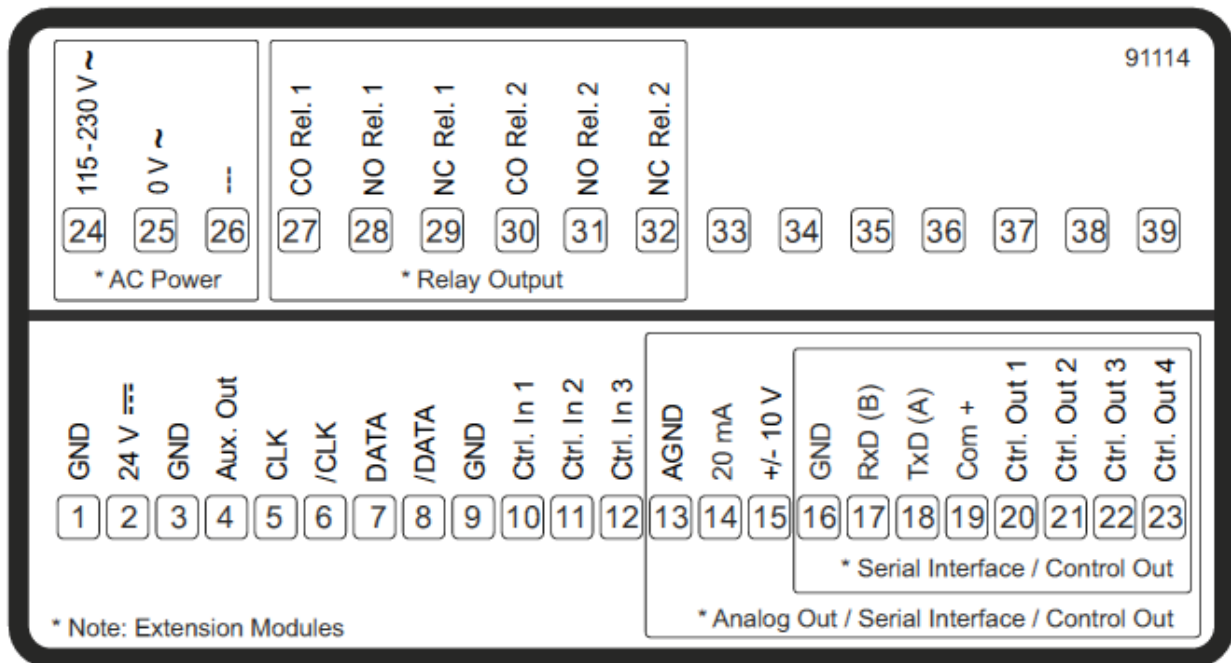

#### 3.1. DC Power Supply

The unit accepts DC supply from 18 to 30 V at the terminals 1 and 2. The power consumption depends on the level of the supply voltage with approx. 100 mA and the additional current required at the Auxiliary Voltage Output.

All GND terminals are internally interconnected.

#### 3.2. Auxiliary Voltage Output

Terminal 3 and 4 provide an auxiliary output for supply of sensors and encoders. The 24 VDC output voltage depends on the power supply (see Technical data). The auxiliary voltage output is switchable from 24 VDC to 5 VDC.



### 3.3. SSI-Inputs

At Terminal 5, 6, 7 and 8, the connection is available for SSI signals. The basic settings must be set in the menu SSI PROPERTIES.

Wiring for **MODE Master**:

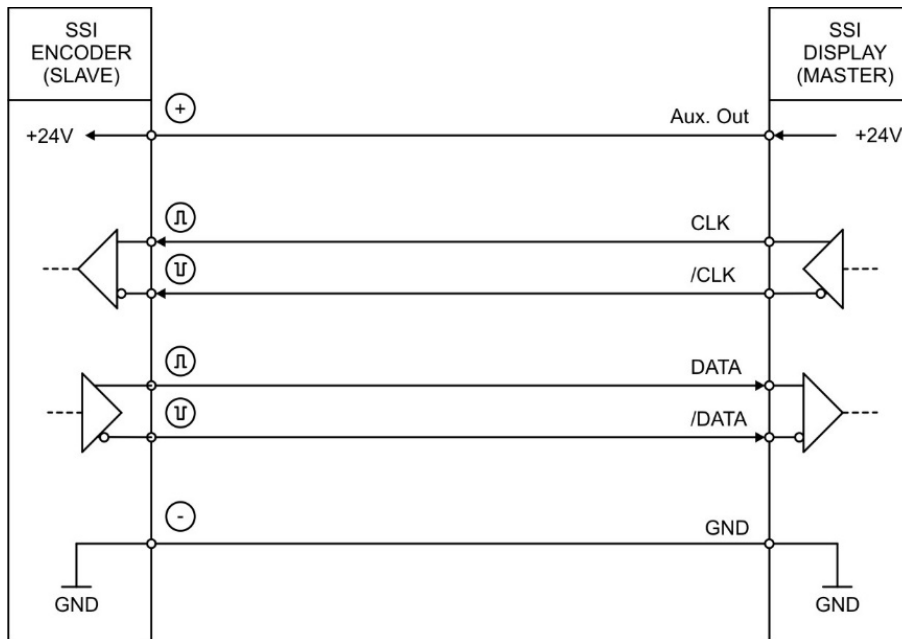

Wiring for **MODE Slave**:

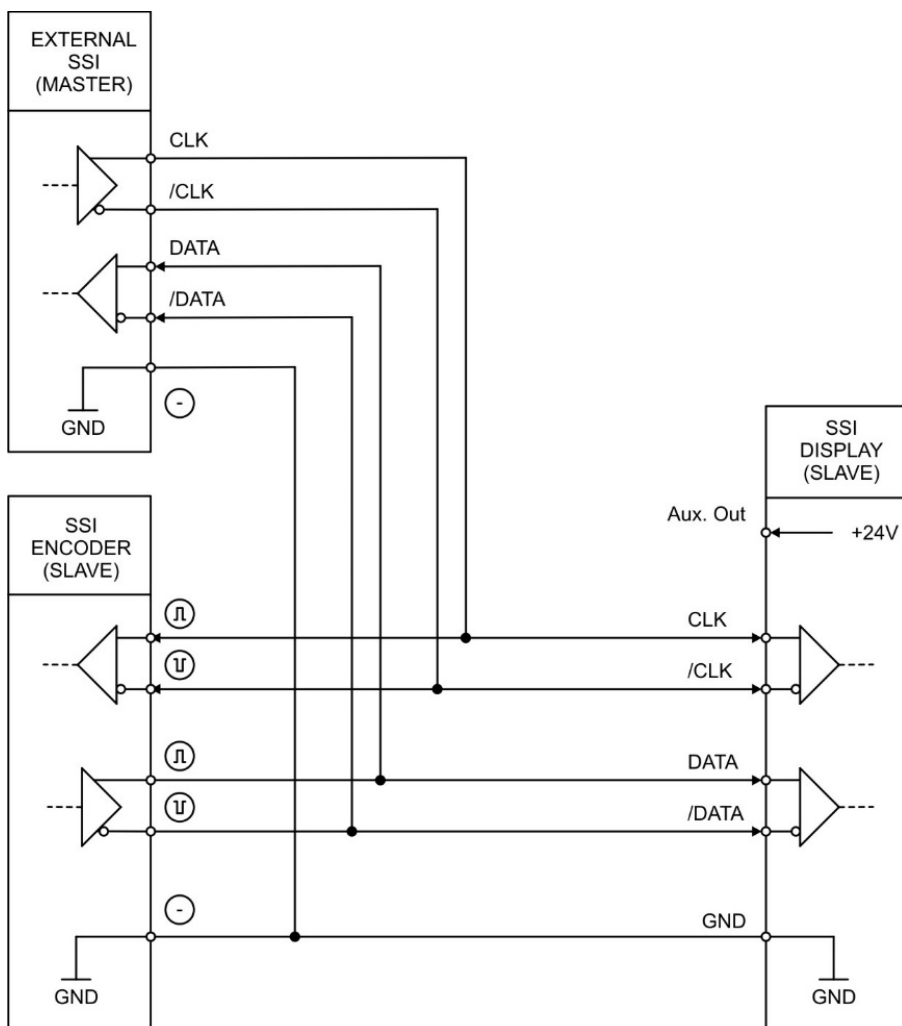

### 3.4. Control Inputs

The three control inputs at terminal 10, 11 and 12 have HTL PNP characteristics. In the COMMAND MENU the programmable functions for the control inputs can be assigned. Available functions are: reset the display value, display switching, locking the touch screen or release the lock function of the control or relay outputs.

Wiring of the control inputs:

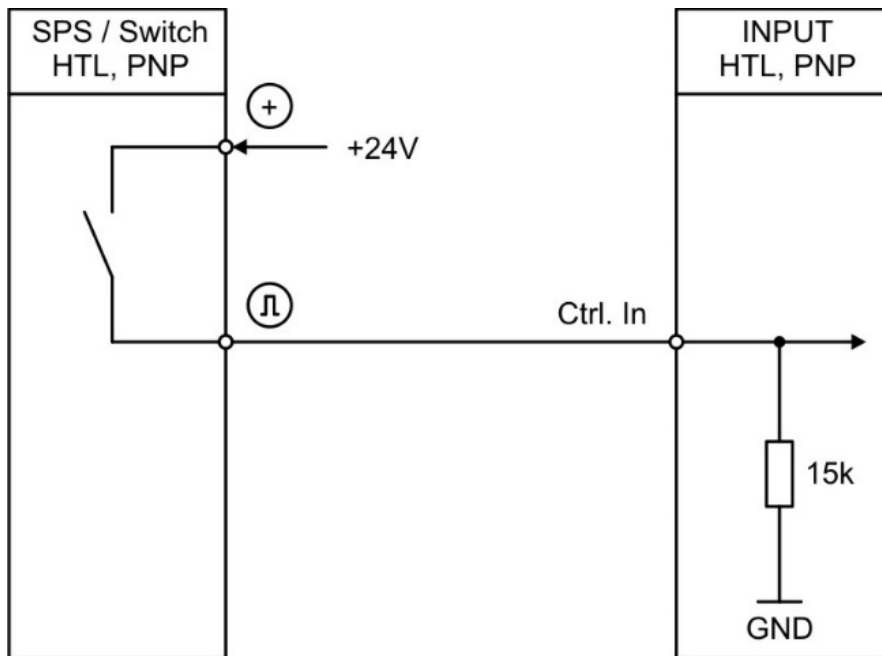

Unconnected PNP inputs are always "LOW".  
All inputs are designed to receive impulses from electrical impulse sources.

#### Notice for mechanical switching contacts:

When exceptionally mechanical contacts are used, please connect an external capacitor between GND (-) and the corresponding input (+). A capacity of 10  $\mu$ F will reduce the input frequency to 20 Hz and miscounting due to contact bouncing will be eliminated.

### 3.5. Analog Output (Option AO/AR)

A 16 bit analog output is available at terminal 13 and 14 / 15  
This output can be configured and scaled in the ANALOG MENU.

The following configuration is possible:

- Voltage output: -10 ... +10 V
- Current output: 0 ... 20 mA
- Current output: 4 ... 20 mA

The analog output is proportional to the display value and is referenced to potential AGND.  
AGND and GND are internally interconnected.



**Important:**  
**A parallel operation with voltage and current output at the analog output is not allowed.**

### 3.6. Serial interface (Option AO/AR/CO/CR)

A serial interface (RS232 or RS485) is available at terminal 16, 17 und 18. This interface can be configured in the SERIAL MENU.

The serial interface RS232 or RS485 can be used:

- for easy setup and commissioning of the units
- to modify settings and parameters during operation
- to read out internal states and actual measuring values by PC or PLC

The following drawing shows the connection to a PC by using a standard Sub-D-9 connector:

Connection of the RS232 interface:

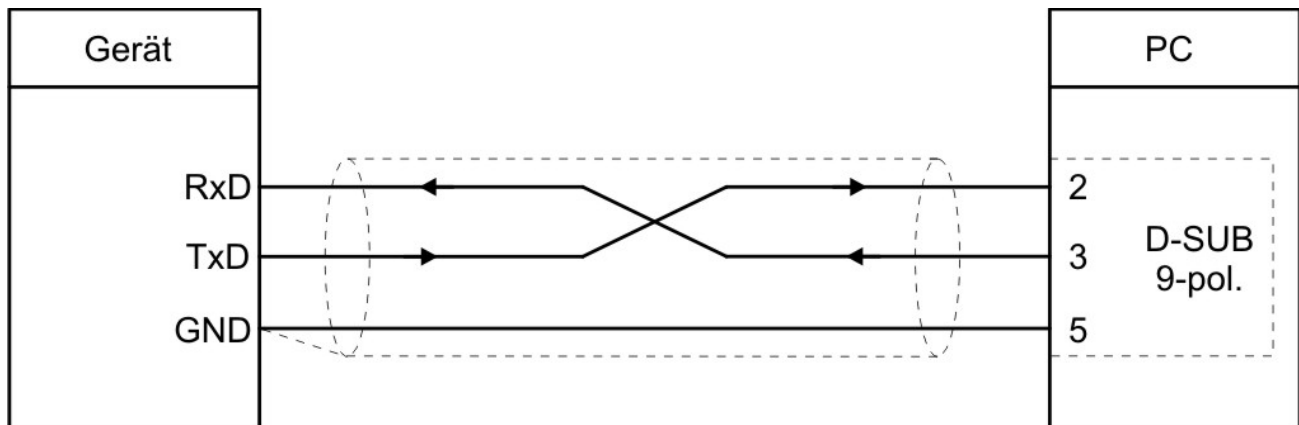

Connection of the RS485 interface:

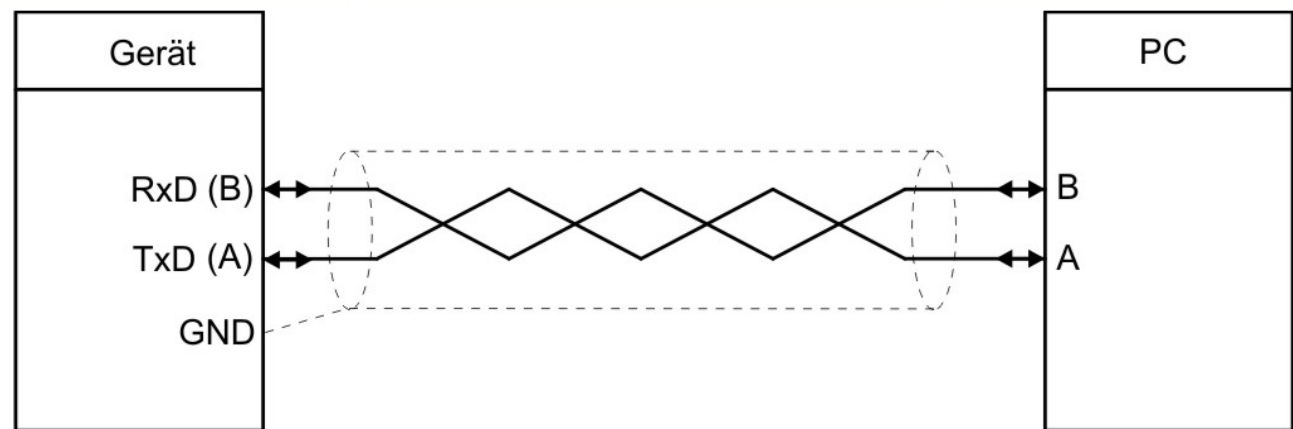

### 3.7. Control-Output (Option AO/AR/CO/CR)

Four control outputs are available at terminal 20, 21, 22 and 23.

Switching conditions can be set in the PRESELECTION MENU. The output Ctrl. Out1 – 4 are fast PNP outputs with a switching capability of 5 – 30 Volt / 200 mA per channel. The switching states is displayed (display with unit and status bar) as C1 ... C4.

The switching voltage of the outputs must be applied to input terminal 19 (COM+). In case of switching inductive loads it is advisable to use external filtering of the coils.

Wiring of the control-outputs:

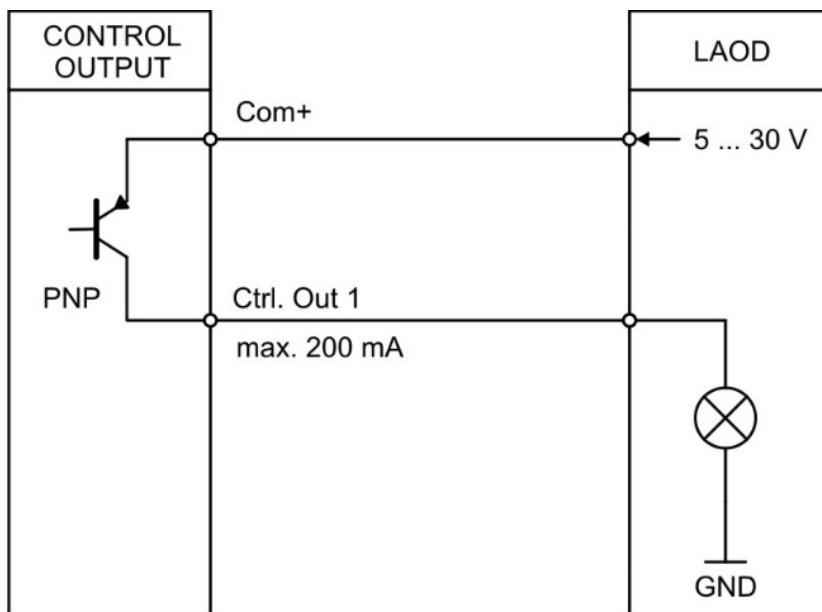

### 3.8. AC Power supply (Option AC)

The unit accepts AC supply from 115 to 230 V at the terminals 24 and 25. The power consumption depends on the level of the supply voltage with approx. 3VA and the additional current required at the auxiliary voltage output.

Devices with option AC can also be supplied with a DC voltage between 18 and 30 VDC via Terminals 1 and 2.

### 3.9. Relay-Output (Option RL)

Two relay outputs with potential-free changeover contacts are available at terminal 27, 28, 28, 30, 31 and 32. Switching conditions can be set in the PRESELECTION MENU. The switching states are displayed (display with unit and status bar) as K1 and K4.

AC-switching capacity max 250 VAC/ max 3 A / 750 VA

DC-switching capacity max 150 VAC/ max 2 A / 50 W

Wiring of the relay outputs

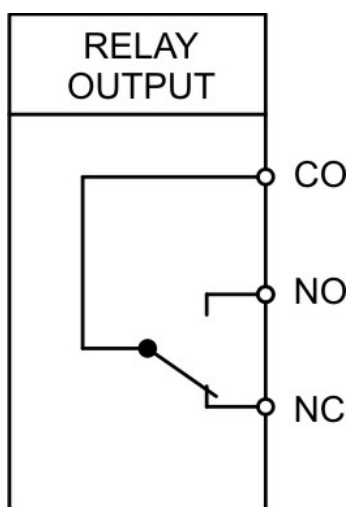

## 4. Display and touch screen

### 4.1. Screen structure for parametrization

The parameter menus and the parameters are described in chapter 5.



#### Start setup procedure:

To edit the parameters, press the touchscreen for 3 seconds.



#### Menu selection:

Select the parameter menu via arrow buttons and confirm with "OK".

The menu selection can be terminated with „C“.



#### Parameter selection:

Select the parameter via arrow buttons and confirm with „OK“.

The parameter selection can be terminated with „C“.

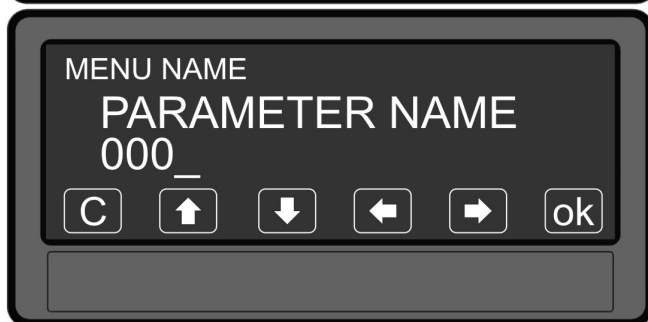

#### Parameter editing:

Edit the parameter via arrow button up and down, shift cursor via left and right and save with „OK“.

The parameter editing can be terminated with „C“.



**Parameter changes becomes active only after closing the menu selection.**

## 4.2. Screen structure in operation

The following displays are available during operation. Depending on the device version and the selected operating mode, only certain representations are displayed.



### Display with unit and status bar

To switch to the next display, press the touch screen.

Control - or Relay status are only shown with Option AO, AR CO, CR or RL.



### Two-line display without units:

#### Diagnostic window:

Read-in value for diagnostic purposes (raw data).

Can be deactivated via the "DIAGNOSTIC DISPLAY" parameter in the display menu. When the diagnostic window is deactivated, process data are displayed.



### Two-line display with units:

To switch to the next display, press the top of the screen.

The desired "source" can be set in the display menu.



### Large Display (4 digits)

To switch to the next display, press the top of the screen.

Only visible in the display menu with activated "LARGE DISPLAY" parameter.



### Display with command keys

Function see "Command menu". To switch to the next display, press the top of the screen.

Continuation "Screen structure in operation":



Display for quick start for enter preselection values (PRESELECTION VALUES)

To switch to the next display, press the top of the screen.

This is only possible with Option AO, AR, CO, CR and RL



Display with minimum and maximum value

To switch to the next display, press the top of the screen or the "skip" button.

The maximum and minimum evaluation is referenced always to the source set in the "SOURCE SINGLE" parameter.

### 4.3. Error Message

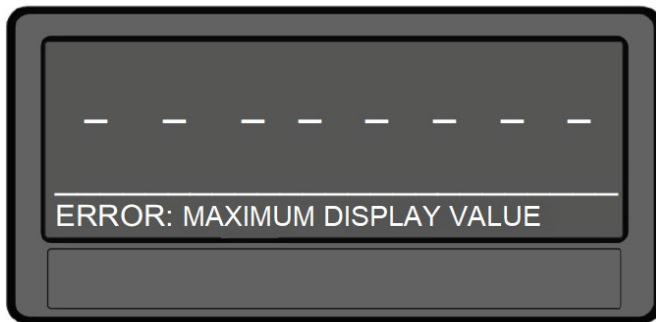

#### ERROR: MAXIMUM DISPLAY VALUE

Display value of the single line display is greater than + 99.999.999

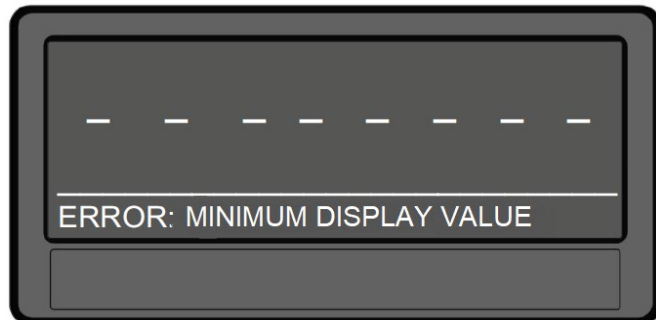

#### ERROR: MINIMUM DISPLAY VALUE

Display value of the single line display is less than -99.999.999

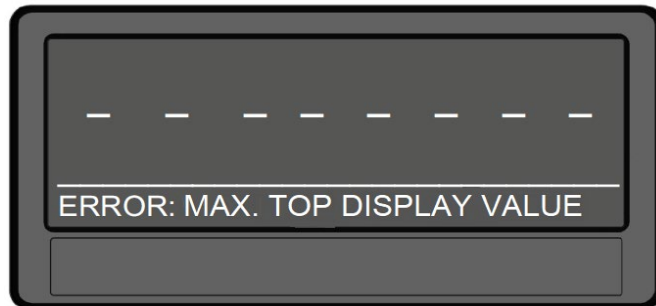

#### ERROR: MAX. TOP DISPLAY VALUE

Top display value of the two-line display is greater than +99.999.999

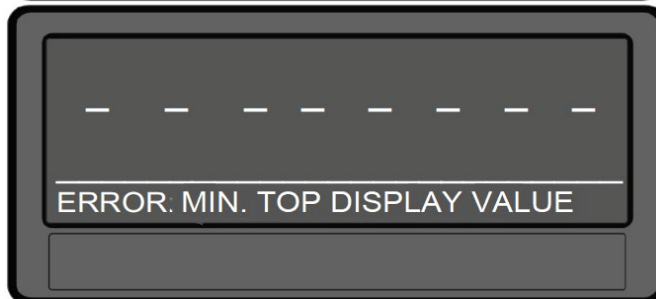

#### ERROR: MIN. TOP DISPLAY VALUE

Top display value of the two-line display is less than -99.999.999

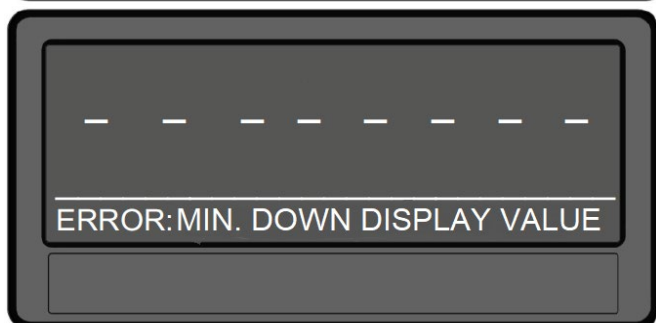

#### ERROR: MAX. DOWN DISPLAY VALUE

Down display value of the two-line display is greater than +99.999.999



Continuation "Error messages":

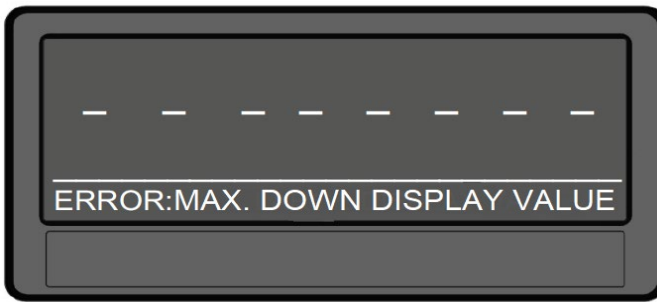

ERROR: MIN. DOWN DISPLAY VALUE

Down display value of the two-line display is less than -99.999.999

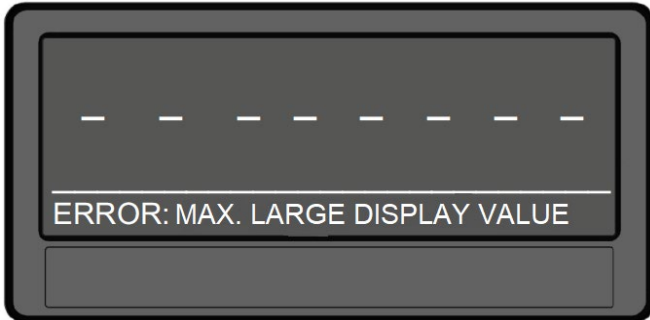

ERROR: MAX. LARGE DISPLAY VALUE

The display value of the large display is greater than + 9999

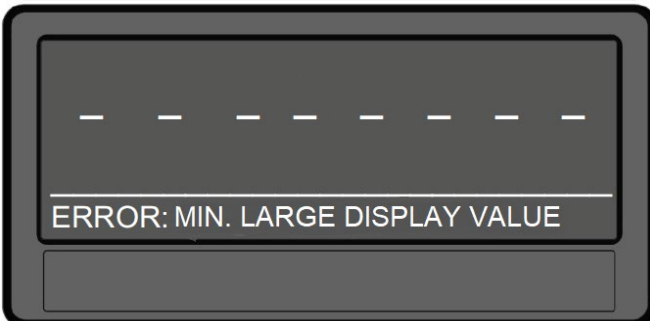

ERROR: MIN. LARGE DISPLAY VALUE

The display value of the large display is less than - 999



ERROR: SSI ERROR BIT SET

The error bit of the SSI encoder is set.



The error messages described are **automatically** reset as soon as the corresponding display value is within the representable range or the error has been corrected accordingly.

With options AO and AR, the analog output is also controlled with 0 V or 0 mA in case of an error.

## 5.Parameter / Overview-Menu Structure

This section provides an overview of the menus and their parameters. The menu names are printed bold and the associated parameters are listed under the menu name. Depending on the device version and the selected operation mode, only the necessary menus / parameters are shown.

<b>Menu / Parameter</b>	<b>Menu / Parameter</b>
<b>GENERAL MENU</b>	<b>PRESELECTION 1 MENU</b>
LINEARIZATION MODE	SOURCE 1
PIN PRESELECTION	MODE 1
PIN PARAMETER	HYSTERESIS 1
FACTORY SETTINGS	PULSE TIME 1
<b>SSI PROPERTIES</b>	OUTPUT TARGET 1
MODE	OUTPUT POLARITY 1
ENCODER RESOLUTION	OUTPUT LOCK 1
BIT PER REVOLUTION	START UP DELAY 1
DATA FORMAT	EVENT COLOR 1
BAUD RATE	<b>PRESELECTION 2 MENU</b>
HIGH BIT	SOURCE 2
LOW BIT	MODE 2
DIRECTION	HYSTERESIS 2
ERROR BIT	PULSE TIME 2
ERROR POLARITY	OUTPUT TARGET 2
ENCODER SUPPLY	OUTPUT POLARITY 2
<b>POSITION SETTINGS</b>	OUTPUT LOCK 2
DISPLAY FORMAT	START UP DELAY 2
FACTOR	EVENT COLOR 2
DIVIDER	<b>PRESELECTION 3 MENU</b>
ADDITIVE VALUE	SOURCE 3
DECIMAL POINT	MODE 3
SCALE UNIT	HYSTERESIS 3
SSI OFFSET	PULSE TIME 3
SSI ZERO	OUTPUT TARGET 3
ROUND LOOP VALUE	OUTPUT POLARITY 3
SAMPLING TIME (S)	OUTPUT LOCK 3
<b>SPEED SETTINGS</b>	START UP DELAY 3
FACTOR	EVENT COLOR 3
DIVIDER	<b>PRESELECTION 4 MENU</b>
DECIMAL POINT	SOURCE 4
SCALE UNIT	MODE 4
AVERAGE FILTER	HYSTERESIS 4
SAMPLING TIME (S)	PULSE TIME 4
<b>PRESELECTION VALUES</b>	OUTPUT TARGET 4
PRESELECTION 1	OUTPUT POLARITY 4
PRESELECTION 2	OUTPUT LOCK 4
PRESELECTION 3	START UP DELAY 4
PRESELECTION 4	EVENT COLOR 4

Continuation "Parameter / Overview-Menu Structure"

Menu / Parameter
<b>SERIAL MENU</b>
UNIT NUMBER
SERIAL BAUD RATE
SERIAL FORMAT
SERIAL INIT
SERIAL PROTOCOL
SERIAL TIMER
SERIAL VALUE
MODBUS
<b>ANALOG MENU</b>
ANALOG SOURCE
ANALOG FORMAT
ANALOG START
ANALOG END
ANALOG GAIN
ANALOG OFFSET
<b>COMMAND MENU</b>
INPUT 1 ACTION
INPUT 1 CONFIG
INPUT 2 ACTION
INPUT 2 CONFIG
INPUT 3 ACTION
INPUT 3 CONFIG

Menu / Parameter
<b>DISPLAY MENU</b>
SOURCE SINGLE
SOURCE DUAL TOP
SOURCE DUAL DOWN
LARGE DISPLAY
START DISPLAY
COLOR
BRIGHTNESS
CONTRAST
SCREEN SAVER
UP-DATE-TIME
FONT
SKIP WINDOW
DIAGNOSTIC DISPLAY
<b>LINEARISATION MENU</b>
SOURCE
P1(X)
P1(Y)
P2(X)
P2(Y)
...
...
P23(X)
P23(Y)
P24(X)
P24(Y)

## 5.1. General Menu

<b>LINEARIZATION MODE</b>		
This parameter defines the linearization function. See chapter 6.4.		
<b>0</b>	<b>OFF</b>	No linearization
<b>1</b>	<b>1 QUADRANT</b>	Linearization in the 1. quadrant
<b>2</b>	<b>4 QUADRANT</b>	Linearization in all 4 quadrants

<b>PIN PRESELECTION</b>		
This parameter defines the PIN-code to lock the quick start of the menu PRESELECTION VALUE for entering the preselection values. (Master PIN 6079). This Lock function is only useful in conjunction with active lock function in PIN PARAMETER.		
	<b>0000</b>	No lock
	...	
	<b>9999</b>	Access after entering PIN-Code 9999

<b>PIN PARAMETER</b>		
This parameter defines the PIN-code for lock function of all parameters (master PIN 6079).		
	<b>0000</b>	No lock
	...	
	<b>9999</b>	Parameterization of the unit after entering PIN-code 9999

<b>FACTORY SETTINGS</b>		
<b>0</b>	<b>NO</b>	No default values are loaded
<b>1</b>	<b>YES</b>	Load default values of all parameters (grey marked default values)

## 5.2. SSI Properties

<b>MODE</b> SSI setting master mode or slave		
<b>0</b>	<b>MASTER</b>	Master-Mode: Clock for SSI encoder comes from the device
<b>1</b>	<b>SLAVE</b>	Slave-Mode: Clock for SSI encoder comes from the external master.

<b>ENCODER RESOLUTION</b> Resolution of the SSI encoder (total number of bits)		
	<b>10</b>	Smallest value
	<b>25</b>	Default value
	<b>32</b>	Highest value

<b>BIT PER REVOLUTION</b> Bit revolution for singleturn		
	<b>10</b>	Smallest value
	<b>13</b>	Default value
	<b>16</b>	Highest value

<b>DATA FORMAT</b> Setting the SSI code (binary or grey)		
<b>0</b>	<b>GRAY CODE</b>	SSI-Code Gray
<b>1</b>	<b>BINARY CODE</b>	SSI-Code Binary

<b>BAUD RATE</b> Clock frequency of SSI telegrams		
<b>0</b>	<b>2 MHZ</b>	N.A.
<b>1</b>	<b>1.5 MHZ</b>	N.A.
<b>2</b>	<b>1 MHZ</b>	Clock frequency 1 MHz
<b>3</b>	<b>500 KHZ</b>	Clock frequency 500 kHz
<b>4</b>	<b>250 KHZ</b>	Clock frequency 250 kHz
<b>5</b>	<b>100 KHZ</b>	Clock frequency 100 kHz

Continuation "SSI Properties":

<b>HIGH BIT</b> (for bit blanking)		
Defines the highest evaluated bit (MSB) for bit blanking. If all bits should be evaluated, HIGH BIT must be set to the given total number of bit.		
	<b>01</b>	Smallest value
	<b>25</b>	Default value
	<b>32</b>	Highest value

<b>LOW BIT</b> (for bit blanking))		
Defines the lowest evaluated bit (MSB) for bit blanking. If all bits should be evaluated, LOW BIT must be set to 01.		
	<b>01</b>	Smallest value
	...	
	<b>32</b>	Highest value

<b>DIRECTION</b>		
Definition of the direction of rotation forward / backward		
	<b>0 FORWARD</b>	Forward
	<b>1 REVERSE</b>	Backwards

<b>ERROR BIT</b>		
Defines the encoder monitoring and the error bit		
	<b>0</b>	No error bit available. Review on connected sensor is turned off.
	...	
	<b>32</b>	Position of the error bits to be evaluated Review on connected sensor is turned on.

<b>ERROR POLARITY</b>		
Defined the polarity of the error bit in the case of an error		
	<b>0</b>	Bit is low in the case of an error
	<b>1</b>	Bit is high in the case of an error

<b>ENCODER SUPPLY</b>		
This parameter defines the output voltage of the auxiliary output (aux out)		
	<b>0 24VDC SUPPLY</b>	24 VDC encoder supply
	<b>1 5VDC SUPPLY</b>	5V VDC encoder supply

## 5.3. Position Settings

The settings for the position display are defined in this menu.

<b>DISPLAY FORMAT</b>		
This parameter selects the Display Format of the position display. The decimal point is set automatically when the format is 999999: 59 or 9999: 59: 59. The display value depends on the scaling (FACTOR, DIVIDER and ADDITIVE VALUE)		
<b>0</b>	<b>99999999</b>	without format adaptation
<b>1</b>	<b>999999:59</b>	Display in degrees: angle-minutes or angle-minutes: seconds
<b>2</b>	<b>9999:59:59</b>	Display in degrees: angle-minutes: seconds

<b>FACTOR</b> (multiplication factor)		
This parameter defines the factor for the position display.		
	<b>-99999999</b>	Smallest value
	<b>1</b>	Default value
	<b>99999999</b>	Highest value

<b>DIVIDER</b>		
This parameter defines the divisor for the position display.		
	<b>-99999999</b>	Smallest value
	<b>1</b>	Default value
	<b>99999999</b>	Highest value

<b>ADDITIVE VALUE</b>		
This parameter defines an additive constant for the position display		
	<b>-99999999</b>	Smallest value
	<b>0</b>	Default value
	<b>99999999</b>	Highest value

<b>DECIMAL POINT</b>		
This setting defines the position of the decimal point for the position display.		
<b>0</b>	<b>NO</b>	No decimal point
<b>1</b>	<b>0000000.0</b>	Decimal point at the specified position
<b>2</b>	<b>000000.00</b>	Decimal point at the specified position
<b>3</b>	<b>00000.000</b>	Decimal point at the specified position
<b>4</b>	<b>0000.0000</b>	Decimal point at the specified position
<b>5</b>	<b>000.00000</b>	Decimal point at the specified position
<b>6</b>	<b>00.000000</b>	Decimal point at the specified position
<b>7</b>	<b>0.0000000</b>	Decimal point at the specified position

Continuation "Position Settings":

<b>SCALE UNIT</b>																																																																																																		
This parameter defines which unit is shown on the display for the position indication. It doesn't affect the display value.																																																																																																		
The decimal point for decimal places is set in the DECIMAL POINT parameter.																																																																																																		
<b>0</b>	<b>inch</b>	Default																																																																																																
<b>1</b>	<b>feet</b>																																																																																																	
<b>2</b>	<b>mm</b>																																																																																																	
<b>3</b>	<b>cm</b>																																																																																																	
<b>4</b>	<b>m</b>																																																																																																	
<b>5</b>	<b>km</b>																																																																																																	
<b>6</b>	<b>dm</b>																																																																																																	
<b>7</b>	<b>Grad</b>																																																																																																	
<b>8</b>	<b>degree</b>																																																																																																	
<b>9</b>	<b>Min:Sec</b>																																																																																																	
<b>10</b>	<b>H:M:S</b>																																																																																																	
<b>11</b>	<b>inc/s</b>																																																																																																	
<b>12</b>	<b>inch/s</b>																																																																																																	
<b>13</b>	<b>feet/s</b>																																																																																																	
<b>14</b>	<b>mm/s</b>																																																																																																	
<b>15</b>	<b>cm/s</b>																																																																																																	
<b>16</b>	<b>m/s</b>																																																																																																	
<b>17</b>	<b>km/s</b>																																																																																																	
<b>18</b>	<b>dm/s</b>																																																																																																	
<b>19</b>	<b>inch/min</b>																																																																																																	
<b>20</b>	<b>feet/min</b>																																																																																																	
<b>21</b>	<b>mm/min</b>																																																																																																	
<b>22</b>	<b>cm/min</b>																																																																																																	
<b>23</b>	<b>m/min</b>																																																																																																	
<b>24</b>	<b>km/min</b>																																																																																																	
<b>25</b>	<b>dm/min</b>																																																																																																	
<b>26</b>	<b>inch/h</b>																																																																																																	
<b>27</b>	<b>feet/h</b>																																																																																																	
<b>28</b>	<b>km/h</b>																																																																																																	
<b>29</b>	<b>Edit Unit</b>	<p>This parameter can edit a customer-specific unit with max. 16 digits. The Edit Unit Menu is opened with the "OK" button. A unit can be created with the arrow keys (by keeping the arrow keys pressed, the symbols are "scrolled" in fast forward). Key "OK" saves the Edit Unit Menu. Key "C" closes the Edit Unit Menu.</p> <table border="1"> <tbody> <tr> <td></td><td>!</td><td>"</td><td>#</td><td>\$</td><td>%</td><td>&amp;</td><td>'</td><td>(</td><td>)</td><td>*</td><td>+</td><td>,</td><td>-</td><td>.</td><td>/</td> </tr> <tr> <td>0</td><td>1</td><td>2</td><td>3</td><td>4</td><td>5</td><td>6</td><td>7</td><td>8</td><td>9</td><td>:</td><td>;</td><td>&lt;</td><td>=</td><td>&gt;</td><td>?</td> </tr> <tr> <td>@</td><td>A</td><td>B</td><td>C</td><td>D</td><td>E</td><td>F</td><td>G</td><td>H</td><td>I</td><td>J</td><td>K</td><td>L</td><td>M</td><td>N</td><td>O</td> </tr> <tr> <td>P</td><td>Q</td><td>R</td><td>S</td><td>T</td><td>U</td><td>V</td><td>W</td><td>X</td><td>Y</td><td>Z</td><td>[</td><td>\</td><td>]</td><td>^</td><td>_</td> </tr> <tr> <td>`</td><td>a</td><td>b</td><td>c</td><td>d</td><td>e</td><td>f</td><td>g</td><td>h</td><td>i</td><td>j</td><td>k</td><td>l</td><td>m</td><td>n</td><td>o</td> </tr> <tr> <td>p</td><td>q</td><td>r</td><td>s</td><td>t</td><td>u</td><td>v</td><td>w</td><td>x</td><td>y</td><td>z</td><td>{</td><td> </td><td>}</td><td>~</td><td></td> </tr> </tbody> </table>		!	"	#	\$	%	&	'	(	)	*	+	,	-	.	/	0	1	2	3	4	5	6	7	8	9	:	;	<	=	>	?	@	A	B	C	D	E	F	G	H	I	J	K	L	M	N	O	P	Q	R	S	T	U	V	W	X	Y	Z	[	\	]	^	_	`	a	b	c	d	e	f	g	h	i	j	k	l	m	n	o	p	q	r	s	t	u	v	w	x	y	z	{		}	~	
	!	"	#	\$	%	&	'	(	)	*	+	,	-	.	/																																																																																			
0	1	2	3	4	5	6	7	8	9	:	;	<	=	>	?																																																																																			
@	A	B	C	D	E	F	G	H	I	J	K	L	M	N	O																																																																																			
P	Q	R	S	T	U	V	W	X	Y	Z	[	\	]	^	_																																																																																			
`	a	b	c	d	e	f	g	h	i	j	k	l	m	n	o																																																																																			
p	q	r	s	t	u	v	w	x	y	z	{		}	~																																																																																				



Continuation "Position Settings":

**SSI OFFSET**

In the case of a „RESET/SET VALUE“ command (via key command, control input or PC user interface) the not yet scaled, currently acquired position value (after bit suppression and possibly performed encoder zero offset) is transferred to the "SSI OFFSET" parameter and the display zeroed. From the new display zero point, you can now move in positive and negative direction, depending on the direction of rotation.  
(Display offset)

	<b>0</b>	Smallest value
	...	
	<b>999999999</b>	Highest value

**SSI ZERO**

In the case of a "ZERO POSITION" command (via key command or control input), the current SSI position of the encoder is transferred to the "SSI ZERO" parameter and the actual encoder zero point is shifted accordingly. (Encoder zero offset)

	<b>0</b>	Smallest value
	...	
	<b>999999999</b>	Highest value

**ROUND LOOP VALUE**

Defines the number of encoder steps when a round-loop function is desired.

	<b>0</b>	Normal display of the encoder data, round-loop function is turned off.
	...	
	<b>99999999</b>	Number of steps for the round-loop function.

**SAMPLING TIME (S)**

Determines the read cycle for the SSI signal in the Master MODE.

Note:

The sampling time (S) of the position detection must always be set smaller than the sampling time (S) of the speed measurement.

	<b>0.001</b>	Minimum measurement time in seconds
	<b>0.010</b>	Default value
	<b>9.999</b>	Maximum measurement time in seconds

## 5.4. Speed Settings

The settings for the speed display are defined in this menu.

<b>FACTOR</b> (multiplication factor)		
This parameter defines the factor for the speed display.		
Dieser Parameter definiert den Faktor für die Geschwindigkeitsanzeige.		
<i>Note:</i>		
With the default settings (FACTOR = 1 and DIVIDER = 1) the displayed speed is to be interpreted as the difference between the covered SSI increments per second. [SSI Inc / s]		
	<b>-99999999</b>	Smallest value
	<b>1</b>	Default value
	<b>99999999</b>	Highest Wert

<b>DIVIDER</b>		
This parameter defines the divisor for the speed display.		
<i>Note:</i>		
With the default settings (FACTOR = 1 and DIVIDER = 1) the displayed speed is to be interpreted as the difference between the covered SSI increments per second. [SSI Inc / s]		
	<b>-99999999</b>	Smallest value
	<b>1</b>	Default value
	<b>99999999</b>	Highest value

<b>DECIMAL POINT</b>		
This setting defines the position of the decimal point for the speed display.		
	<b>0 NO</b>	No decimal point
	<b>1 000000.0</b>	Decimal point at the specified position
	<b>2 000000.00</b>	Decimal point at the specified position
	<b>3 00000.000</b>	Decimal point at the specified position
	<b>4 0000.0000</b>	Decimal point at the specified position
	<b>5 000.00000</b>	Decimal point at the specified position
	<b>6 00.000000</b>	Decimal point at the specified position
	<b>7 0.0000000</b>	Decimal point at the specified position

<b>SCALE UNIT</b>		
This parameter defines which unit is shown on the display for the speed indication. It doesn't affect the display value.		
The decimal point for decimal places is set in the DECIMAL POINT parameter.		
For a list of the adjustable units, see the "SCALE UNIT" parameter in the "Position Settings" menu.		

<b>AVERAGE FILTER</b>		
Switchable averaging to avoid display fluctuations in the speed display.		
	<b>0</b>	No average value
	<b>1</b>	Flowing mean value with 2 cycles
	<b>2</b>	Flowing mean value with 4 cycles
	<b>3</b>	Flowing mean value with 8 cycles
	<b>4</b>	Flowing mean value with 16 cycles

Continuation "Speed Settings":

<b>SAMPLING TIME (S)</b>		
Determines the sampling interval in which the speed evaluation is carried out.		
<i>Note:</i>		
The sampling time (S) of the speed measurement must always be set higher than the read-in cycle of two consecutive SSI telegrams.		
	<b>0.1</b>	Minimum sampling interval in seconds
	<b>0.5</b>	Default value
	<b>9.9</b>	Maximum sampling interval in seconds

## 5.5. Preselection Values

This menu is used to set the preselection values or the switching points. The preselection values always refer to the "SOURCE" selected in the PRESELECTION MENU.

The preselection values / switching points are always referred to the display value.

This menu is only available for devices with option CO, CR, AO, AR or RL.

<b>PRESELECTION 1</b>		
Preselection / switching point 1		
	<b>-99999999</b>	Smallest value
	<b>1000</b>	Default value
	<b>+99999999</b>	Highest value

<b>PRESELECTION 2</b>		
Preselection / switching point 2		
	<b>-99999999</b>	Smallest value
	<b>2000</b>	Default value
	<b>+99999999</b>	Highest value

<b>PRESELECTION 3</b>		
Preselection / switching point 3		
	<b>-99999999</b>	Smallest value
	<b>3000</b>	Default value
	<b>+99999999</b>	Highest value

<b>PRESELECTION 4</b>		
Preselection / switching point 4		
	<b>-99999999</b>	Smallest value
	<b>40000</b>	Default value
	<b>+99999999</b>	Highest value

## 5.6. Preselection 1 Menu

In this menu, the parameters of the reference source, the switching conditions and other definitions for preset value / switching point 1 are set.

This function is only available for devices with option CO, CR, AO, AR or RL.

<b>SOURCE 1</b>		
This parameter defines the reference source for preselection 1.		
<b>0</b>	<b>POSITION</b>	Result of the position measurement
<b>1</b>	<b>SPEED</b>	Result of the speed measurement

<b>MODE 1</b>		
Switching conditions for preselection 1. Output/ relay/ display switches under the following conditions:		
<b>0</b>	<b> RESULT &gt;= PRES </b>	Absolute value of the display value is greater or equal absolute value of PRESELECTION 1 With HYSTERESIS 1 not equal 0 the following switching condition is applied: Display value >= PRESELECTION 1 → ON, Display value < PRESELECTION 1 – HYSTERESIS 1 → OFF
<b>1</b>	<b> RESULT &lt;= PRES </b>	Absolute value of the display value is less or equal absolute value of PRESELECTION 1 (start-up suppression (START UP DELAY) is advisable) With HYSTERESIS 1 not equal 0 the following switching condition is applied: Display value <= PRESELECTION 1 → ON, Display value > PRESELECTION 1 + HYSTERESIS 1 → OFF
<b>2</b>	<b> RESULT = PRES </b>	Absolute value of the display value is equal absolute value of PRESELECTION 1 A range (Preselection +/- ½ Hysteresis) can be defined and monitored in conjunction with the hysteresis. With HYSTERESIS 1 not equal 0 the following switching condition is applied: Display value > PRESELECTION 1 + ½ HYSTERESIS 1 → OFF, Display value < PRESELECTION 1 - ½ HYSTERESIS 1 → OFF
<b>3</b>	<b>RESULT&gt;=PRES</b>	Display value is greater or equal PRESELECTION 1, e.g. overspeed With HYSTERESIS 1 not equal 0 the following switching condition is applied: Display value >= PRESELECTION 1 → ON, Display value < PRESELECTION 1 – HYSTERESIS 1 → OFF
<b>4</b>	<b>RESULT&lt;=PRES</b>	Display value is less or equal PRESELECTION 1, e.g. underspeed (start-up suppression (START UP DELAY) is advisable) With HYSTERESIS 1 not equal 0 the following switching condition is applied: Display value <= PRESELECTION 1 → ON, Display value > PRESELECTION 1 + HYSTERESIS 1 → OFF
<b>5</b>	<b>RESULT=PRES</b>	Display value is equal PRESELECTION 1. A range (Preselection +/- ½ Hysteresis) can be defined and monitored in conjunction with the hysteresis. With HYSTERESIS 1 not equal 0 the following switching condition is applied: Display value > PRESELECTION 1 + ½ HYSTERESIS 1 → OFF, Display value < PRESELECTION 1 - ½ HYSTERESIS 1 → OFF
<b>6</b>	<b>RES&gt;=PRES-TRAIL</b>	Trailing PRESELECTION 1: Display value is greater or equal PRESELECTION 2 – PRESELECTION 1 → ON, PRESELECTION 1 is the trailing value from PRESELECTION 2
<b>7</b>	<b>ERROR SET</b>	Error message for device errors

Continuation "Preselection 1 Menu":

<b>HYSTERESIS 1</b>		
This parameter defines the switching hysteresis of the switch-off point for preselection 1		
	<b>0</b>	No switching hysteresis
	...	
	<b>99999</b>	Switching hysteresis of 99999

<b>PULSE TIME 1 (S)</b>		
Duration of output pulse for the switching condition of preselection 1		
	<b>0,000</b>	No output pulse (static signal)
	...	
	<b>60,000</b>	Pulse duration of 60 seconds

<b>OUTPUT TARGET 1</b>		
Assignment of an output or relay for the switching condition of preselection 1. If more than one switching condition is assigned to one output / relay, the output is set when at least one switching condition is true		
	<b>0 NO</b>	No assignment
	<b>1 CTRL OUT 1</b>	Switching condition assigned to "Ctrl. Out 1"
	<b>2 CTRL OUT 2</b>	Switching condition assigned to "Ctrl. Out 2"
	<b>3 CTRL OUT 3</b>	Switching condition assigned to "Ctrl. Out 3"
	<b>4 CTRL OUT 4</b>	Switching condition assigned to "Ctrl. Out 4"
	<b>5 RELAY 1</b>	Switching condition assigned to "Rel. 1"
	<b>6 RELAY 2</b>	Switching condition assigned to "Rel. 2"

<b>OUTPUT POLARITY 1</b>		
Polarity for the switching condition of preselection 1		
	<b>0 ACTIVE HIGH</b>	Switching condition is true → Active „HIGH“
	<b>1 ACTIVE LOW</b>	Switching condition is true → Active „LOW“

<b>OUTPUT LOCK 1</b>		
Latch for the switching condition of preselection 1		
	<b>0 NO</b>	No latch for preselection
	<b>1 YES</b>	Latch for preselection (command LOCK RELEASE will clear latch)

Continuation "Preselection 1 Menu":

**START UP DELAY 1 (S)**

Start-up suppression for the switching condition of preselection 1. Time to start the monitoring function.

This adjustment is only valid for the switching condition  $|\text{RESULT}| \leq |\text{PRES}|$  or  $\text{RESULT} \leq \text{PRES}$ . START UP DELAY is set to this parameter, when the display value is 0. The timer starts with a display value not equal to 0. The monitoring function remains deactivated until the set time has elapsed.

(Start Up Delay 3 and 4 have an automatic start up suppression).

	<b>0.000</b>	No start-up suppression
	...	
	<b>60.000</b>	Start-up suppression in seconds

**EVENT COLOR 1**

Event-depending change of the display color for the switching condition of preselection 1. EVENT COLOR 1 has the lowest priority. EVENT COLOR 2 ... 4 are allowed to overwrite this color change.

	<b>0</b>	<b>NO CHANGE</b>	No color change.
	<b>1</b>	<b>CHANGE TO RED</b>	Color change to red
	<b>2</b>	<b>CHANGE TO GREEN</b>	Color change to green
	<b>3</b>	<b>CHANGE TO YELLOW</b>	Color change to yellow

## 5.7. Preselection 2 Menu

### SOURCE 2

This parameter defines the reference source for preselection 2, see PRESELECTION 1 MENU.

### MODE 2

Switching conditions for preselection 2., see chapter PRESELECTION 1 MENU (except the trailing value)

		see chapter PRESELECTION 1 MENU
6	<b>RES&gt;=PRES-TRAIL</b>	Trailing preselection 2: Display value is greater or equal to PRESELECTION 1 – PRESELECTION 2 → ON, PRESELECTION 2 is the trailing preselection from PRESELECTION 1.

### HYSTERESIS 2

This parameter defines the switching hysteresis of the switch-off point for preselection 2.  
See chapter PRESELECTION 1 MENU.

### PULSE TIME 2 (S)

Duration of output pulse for the switching condition of preselection 2.  
See chapter PRESELECTION 1 MENU.

### OUTPUT TARGET 2

Assignment of an output or relay for the switching condition of preselection 2.  
See chapter PRESELECTION 1 MENU.

### OUTPUT POLARITY 2

Polarity for the switching condition of preselection 2.  
See chapter PRESELECTION 1 MENU.

### OUTPUT LOCK 2

Latch for the switching condition of preselection 2.  
See chapter PRESELECTION 1 MENU.

### START UP DELAY 2 (S)

Start-up suppression for the switching condition of preselection 2.  
See chapter PRESELECTION 1 MENU.  
(Start Up Delay 3 and 4 have an automatic start up suppression).

### EVENT COLOR 2

Event-dependent change of the display color for the switching condition of preselection 2.  
See chapter PRESELECTION 1 MENU.

## 5.8. Preselection 3 Menu

### SOURCE 3

This parameter defines the reference source for preselection 3, see PRESELECTION 1 MENU.

### MODE 3

Switching conditions for preselection 3., see chapter PRESELECTION 1 MENU (except the trailing value)

		See chapter PRESELECTION 1 MENU
6	RES>=PRES-TRAIL	Trailing preselection 3: Display value is greater or equal to PRESELECTION 4 – PRESELECTION 3 → ON, PRESELECTION 3 is the trailing preselection from PRESELECTION 4.

### HYSTERESIS 3

This parameter defines the switching hysteresis of the switch-off point for preselection 3.  
See chapter PRESELECTION 1 MENU.

### PULSE TIME 3 (S)

Duration of output pulse for the switching condition of preselection 3.  
See chapter PRESELECTION 1 MENU.

### OUTPUT TARGET 3

Assignment of an output or relay for the switching condition of preselection 3.  
See chapter PRESELECTION 1 MENU.

### OUTPUT POLARITY 3

Polarity for the switching condition of preselection 3.  
See chapter PRESELECTION 1 MENU.

### OUTPUT LOCK 3

Latch for the switching condition of preselection 3.  
See chapter PRESELECTION 1 MENU.

### START UP DELAY 3

Start-up suppression for the switching condition of preselection 3.

Time to start the monitoring function.

This adjustment is only valid for the switching condition  $|\text{RESULT}| \leq |\text{PRES}|$  or  $\text{RESULT} \leq \text{PRES}$ .

Automatic start up suppression is activated, when the parameter is switched on and the display value is 0. The monitoring function remains deactivated until the preset value / switching point is exceeded for the first time.

(Start Up Delay 1 and 2 have a time-dependent start up suppression).

0	OFF	No start-up suppression
1	AUTO	Automatic start up suppression, Until the preselection value / switching point is exceeded for the first time.

### EVENT COLOR 3

Event-depending change of the display color for the switching condition of preselection 3.  
See chapter PRESELECTION 1 MENU.



## 5.9. Preselection 4 Menu

### SOURCE 4

This parameter defines the reference source for preselection 4, see PRESELECTION 1 MENU.

### MODE 4

Switching conditions for preselection 4., see chapter PRESELECTION 1 MENU (except the trailing value)

		See chapter PRESELECTION 1 MENU
6	RES>=PRES-TRAIL	Trailing preselection 4: Display value is greater or equal to PRESELECTION 3 – PRESELECTION 4 → ON, PRESELECTION 4 is the trailing preselection from PRESELECTION 3.

### HYSTERESIS 4

This parameter defines the switching hysteresis of the switch-off point for preselection 4.  
See chapter PRESELECTION 1 MENU.

### PULSE TIME 4 (S)

Duration of output pulse for the switching condition of preselection 4.  
See chapter PRESELECTION 1 MENU.

### OUTPUT TARGET 4

Assignment of an output or relay for the switching condition of preselection 4.  
See chapter PRESELECTION 1 MENU.

### OUTPUT POLARITY 4

Polarity for the switching condition of preselection 4.  
See chapter PRESELECTION 1 MENU.

### OUTPUT LOCK 4

Latch for the switching condition of preselection 4.  
See chapter PRESELECTION 1 MENU.

### START UP DELAY 4

Start-up suppression for the switching condition of preselection 4. See chapter PRESELECTION 3 MENU.

This adjustment is only valid for the switching condition  $|\text{RESULT}| \leq |\text{PRES}|$  or  $\text{RESULT} \leq \text{PRES}$ . Automatic start up suppression is activated, when the parameter is switched on and the display value is 0. The monitoring function remains deactivated until the preset value / switching point is exceeded for the first time.

(Start Up Delay 1 and 2 have a time-dependent start up suppression).

	0	OFF	No start-up suppression
	1	AUTO	Automatic start up suppression, Until the preselection value / switching point is exceeded for the first time.

### EVENT COLOR 4

Event-dependent change of the display color for the switching condition of preselection 4.  
See chapter PRESELECTION 1 MENU.

## 5.10. Serial Menu

This menu defines the basic settings of serial interface.

This function is only available for devices with option CO/CR or AO/AR.

<b>UNIT NUMBER</b>		
This parameter defines serial device addresses. The addresses between 11 and 99 can be assigned to the devices. Addresses with zero are not allowed, there are used as broadcast addresses.		
	<b>11</b>	Smallest address
	...	
	<b>99</b>	Highest address

<b>SERIAL BAUD RATE</b>		
This parameter defines the serial baud rate		
	<b>0</b>	<b>9600</b> 9600 baud
	<b>1</b>	<b>19200</b> 19200 baud
	<b>2</b>	<b>38400</b> 38400 baud

<b>SERIAL FORMAT</b>					
This parameter defines the bit data format.					
	<b>0</b>	<b>7-EVEN-1</b>	7 data	Parity even	1 Stop
	<b>1</b>	<b>7-EVEN-2</b>	7 data	Parity even	2 Stops
	<b>2</b>	<b>7-ODD-1</b>	7 data	Parity odd	1 Stop
	<b>3</b>	<b>7-ODD-2</b>	7 data	Parity odd	2 Stops
	<b>4</b>	<b>7-NONE-1</b>	7 data	no Parity	1 Stop
	<b>5</b>	<b>7-NONE-2</b>	7 data	no Parity	2 Stops
	<b>6</b>	<b>8-EVEN-1</b>	8 data	Parity even	1 Stop
	<b>7</b>	<b>8-ODD-1</b>	8 data	Parity odd	1 Stop
	<b>8</b>	<b>8-NONE-1</b>	8 data	no Parity	1 Stop
	<b>9</b>	<b>8-NONE-2</b>	8 data	no Parity	2 Stops

<b>SERIAL INIT</b>		
With settings larger than 9600 the initialization time can be reduced.		
	<b>0</b>	<b>NO</b> Initialization with 9600 baud. Then the device operates with the value selected by the user.
	<b>1</b>	<b>YES</b> Initialization with the baud rate set by SERIAL BAUD RATE. Then the device operates with the value selected by the user.

Continuation "Serial Menu":

<b>SERIAL PROTOCOL</b>													
Determines the sequence of characters send, when using the serial output for cyclic data transmission under time control (xxxxxxx = value SERIAL VALUE). Setting „1“ removes the unit address from the string which allows a slight faster transmission cycle.													
	<b>0</b>	Transmission report = Unit No., +/-, data, LF, CR											
		1	1	+/-	X	X	X	X	X	X	X	LF	CR
	<b>1</b>	Transmission report = +/-, data, LF, CR											
		+/-	X	X	X	X	X	X	X	X	X	LF	CR

<b>SERIAL TIMER (S)</b>	
This register determines the cycle time in seconds for cycling transmission of SERIAL VALUE when using the serial output. (On a serial request, the cycling transmission is stopped for 20 s)	
<b>0,000</b>	All cyclic transmission is switched off. The unit will send data upon a serial request or with command SERIAL PRINT.
...	
<b>60,000</b>	Cycle time in seconds.

<b>SERIAL VALUE</b>			
This parameter defines the value to be transmitted.			
Setting	Code	Register contents	
<b>0</b>	:0	SSI_Position	
<b>1</b>	:1	SSI Data	
<b>2</b>	:2	SSI Single	
<b>3</b>	:3	SSI Rev	
<b>4</b>	:4	SSI Dir Result	
<b>5</b>	:5	SSI Mask Result	
<b>6</b>	:6	Minimal Value	
<b>7</b>	:7	Maximal Value	
<b>8</b>	:8	Result Speed	
<b>9</b>	:9	Result Position	

## 5.11. Analog Menu

This menu defines the basic settings of the analog output.

This function is only available for devices with option AO or AR.

<b>ANALOG SOURCE</b>		
This parameter defines the reference source for the analog output.		
<b>0</b>	<b>POSITION</b>	Result of the position measurement
<b>1</b>	<b>SPEED</b>	Result of the speed measurement

<b>ANALOG FORMAT</b>		
This parameter defines the output characteristics. The analogue output is proportional to the display value.		
With setting ANALOG FORMAT (-10 ... +10 V) in MODE COUNTER the polarity of the analog output depends on the polarity of the display value.		
<b>0</b>	<b>-10...10V</b>	-10 ... +10 V
<b>1</b>	<b>0...20MA</b>	0 ... 20 mA
<b>2</b>	<b>4...20MA</b>	4 ... 20 mA

<b>ANALOG START</b>		
This parameter defines the start value of the analog conversion. This start value is corresponding to the display value for an analog output of 0 V or 0/4 mA.		
	<b>-99999999</b>	Smallest start value
	<b>0</b>	Default value
	<b>+99999999</b>	Highest start value

<b>ANALOG END</b>		
This parameter defines the end value of the analog conversion. This end value is corresponding to the display value for an analog output of (+/-) 10 V or 20mA.		
	<b>-99999999</b>	Smallest end value
	<b>10000</b>	Default Wert
	<b>+99999999</b>	Highest end value

<b>ANALOG GAIN (%)</b>		
This parameter defines the zero offset of the analog output. The ANALOG GAIN is the maximum modulation of the analog output in % terms given up to (+/-) 10 V or 20 mA.		
E.g. 102,00 results in an offset of 10.2 V / 20.4 mA from reaching the ANALOG START value		
E.g. 95,00 results in an offset of 9.5 V / 18 mA from reaching the ANALOG END value		
	<b>0,00</b>	Smallest end value
	<b>100,00</b>	Default Wert
	<b>110,00</b>	Highest end value

<b>ANALOG OFFSET (%)</b>		
This parameter defines the zero offset of the analog output.		
E. g. 0.20 results in an offset of 0.02 V or 0.04 mA from reaching the ANALOG START value		
	<b>-99,99</b>	Smallest offset
	<b>0</b>	Default value
	<b>+99,00</b>	Highest offset

## 5.12. Command Menu

<b>INPUT 1 ACTION</b> _(function Input 1)			
This parameter defines the function of the input "Ctrl. In 1".			
<b>0</b>	<b>NO</b>	No function	
<b>1</b>	<b>RESET/SET VALUE</b>	Transfer of the currently acquired position value (after bit suppression and possibly performed encoder zero offset) in the parameter "SSI Offset" (display zero offset)	(d) (s)
<b>2</b>	<b>FREEZE</b>	Freeze all display values. <u>Note:</u> Analogue output and switching outputs still react to changes!	(s)
<b>3</b>	<b>KEY LOCK</b>	disable touch screen	(s)
<b>4</b>	<b>LOCK RELEASE</b>	Loosen locking of all outputs / relay	(d)
<b>5</b>	<b>RESET MIN/MAX</b>	Reset of the min. / max. values	(d) (s)
<b>6</b>	<b>SERIAL PRINT</b>	Sending of serial data, see parameter SERIAL VALUE	(d)
<b>7</b>	<b>TEACH PRESEL. 1</b>	Current display value is stored as PRESELECTION 1 (The reference source is the "Source" selected in Preselection Menu 1)	(d)
<b>8</b>	<b>TEACH PRESEL. 2</b>	Current display value is stored as PRESELECTION 2 (The reference source is the "Source" selected in Preselection Menu 2)	(d)
<b>9</b>	<b>TEACH PRESEL. 3</b>	Current display value is stored as PRESELECTION 3 (The reference source is the "Source" selected in Preselection Menu 3)	(d)
<b>10</b>	<b>TEACH PRESEL. 4</b>	Current display value is stored as PRESELECTION 4 (The reference source is the "Source" selected in Preselection Menu 4)	(d)
<b>11</b>	<b>SCROLL DISPLAY</b>	Display switching (see display in operation mode)	(d)
<b>12</b>	<b>CLEAR LOOP TIME</b>	Release all latched switching conditions	
<b>13</b>	<b>START PRESELECT</b>	N.A.	
<b>14</b>	<b>ACTIVATE DATA</b>	N.A.	
<b>15</b>	<b>STORE DATA</b>	N.A.	
<b>16</b>	<b>TESTPROGRAM</b>	N.A.	
<b>17</b>	<b>SET RED COLOR</b>	The display lights up red. The color can be changed by the event-dependent color switching in the PRESELECTION 1... 4	(d)
<b>18</b>	<b>SET GREEN COLOR</b>	The display lights up green. The color can be changed by the event-dependent color switching in the PRESELECTION 1... 4	(d)
<b>19</b>	<b>SET YELLOW COLOR</b>	The display lights up yellow The color can be changed by the event-dependent color switching in the PRESELECTION 1... 4	(d)
<b>20</b>	<b>ZERO POSITION</b>	Transfer of the current SSI position in the parameter "SSI Zero" (encoder zero offset)	(d) (s)
<b>21</b>	<b>INC. BRIGHTNESS</b>	Display brightness is increased	(d) (s)
<b>22</b>	<b>DEC. BRIGHTNESS</b>	Display brightness is reduced	(d) (s)

(s) = static switching (level evaluation)  
INPUT CONFIG must be set to active LOW / HIGH

(d) = dynamic switching (edge evaluation)  
INPUT CONFIG must be set to RISING/FALLING EDGE

Continuation "Command Menu":

**INPUT 1 CONFIG**

This parameter defines the switching characteristics of the input "Ctrl. In 1".

<b>0</b>	<b>ACTIVE LOW</b>	Active at „LOW“ (static)
<b>1</b>	<b>ACTIVE HIGH</b>	Active at „HIGH“ (static)
<b>2</b>	<b>RISING EDGE</b>	Activate at rising edge
<b>3</b>	<b>FALLING EDGE</b>	Activate at falling edge

**INPUT 2 ACTION**

This parameter defines the function of the input "Ctrl. In 2".  
See parameter INPUT 1 ACTION.

**INPUT 2 CONFIG**

This parameter defines the switching characteristics of the input "Ctrl. In 2".  
See parameter INPUT 1 CONFIG.

**INPUT 3 ACTION**

This parameter defines the function of the input "Ctrl. In 3".  
See parameter INPUT 1 ACTION.

**INPUT 3 CONFIG**

This parameter defines the switching characteristics of the input "Ctrl. In 3".  
See parameter INPUT 1 CONFIG.

## 5.13. Display Menu

Parameter changes become active only after closing the menu selection.

<b>SOURCE SINGLE</b> (Reference source for the single line display <u>and</u> large display.)		
0	<b>POSITION</b>	Result of the position measurement
1	<b>SPEED</b>	Result of the speed measurement
<b>SOURCE DUAL TOP</b> (Reference source for two-line display, first line)		
0	<b>POSITION</b>	Result of the position measurement
1	<b>SPEED</b>	Result of the speed measurement
<b>SOURCE DUAL DOWN</b> (Reference source for two-line display, second line)		
0	<b>POSITION</b>	Result of the position measurement
1	<b>SPEED</b>	Result of the speed measurement
<b>LARGE DISPLAY</b> This parameter is used to switch the large display on or off. Using the divider ratio, the display value can also be divided accordingly for the large display. (The reference source for the large display is the process value set in the "SOURCE SINGLE" parameter.) The division ratio only affects values without format adjustment. (Display format: 99999999)		
0	<b>NO</b>	Large display switched off.
1	<b>1:1</b>	Large display with divider ratio 1:1
2	<b>1:10</b>	Large display with divider ratio 1:10
3	<b>1:100</b>	Large display with divider ratio 1:100
4	<b>1:1000</b>	Large display with divider ratio 1:1000
5	<b>1:10000</b>	Large display with divider ratio 1:10000
<b>START DISPLAY</b> This parameter defines the start display after switching on the device.		
0	<b>STANDARD</b>	Display with unit and status line
1	<b>LARGE</b>	Large display (only if the "LARGE DISPLAY" parameter is activated)
2	<b>DOUBLE</b>	Double display without units
3	<b>DOUBLE WITH UNITS</b>	Double display with units
4	<b>COMMAND</b>	Display of key commands (only if the "SKIP COMMANDS" parameter is enabled)
5	<b>QUICKSTART</b>	Display with quick start function for entering the preset values (only with option CO / CR / AO / AR / RL)
6	<b>MINIMUM/MAXIMUM</b>	Display of the minimum / maximum values

<b>COLOR</b>			
This parameter defines the display color.			
Event-dependending change of the display color by a switching condition is possible (see PRESELECTION 1...4 MENU)			
Event-dependending changes are only available for devices with option CO, CR, AO, AR or RL.			
	<b>0</b>	<b>RED</b>	Red display
	<b>1</b>	<b>GREEN</b>	Green display
	<b>2</b>	<b>YELLOW</b>	Yellow display

<b>BRIGHTNESS (%)</b>			
This parameter defines the brightness of the display in percent			
	<b>10</b>		Min. brightness
	<b>90</b>		Default value
	<b>100</b>		Max. brightness

<b>CONTRAST</b>			
This parameter defines the viewing angle.			
	<b>0</b>		Viewing angle from top
	<b>1</b>		Viewing angle from centre
	<b>2</b>		Viewing angle from bottom

<b>GREEN SAVER (S)</b>			
This parameter defines the time in seconds until the display is switched off, after the last touch action.			
A new touch action will activate the display again.			
	<b>0</b>		No switch off
	<b>...</b>		
	<b>9999</b>		Longest time to switch off

<b>UP-DATE-TIME (S)</b>			
This parameter defines the update time in seconds of the display only.			
	<b>0,005</b>		Shortest update time
	<b>0,1</b>		Default value
	<b>9,999</b>		Longest update time

<b>FONT</b>			
This parameter defines the setting of the font style.			
	<b>0</b>		Standard
	<b>1</b>		Font 1



<b>SKIP WINDOW</b>		
With this parameter, individual display windows can be skipped.		
	<b>SHOW ALL</b>	All display windows are released.
	<b>SKIP COMMAND KEY</b>	Skipping the display window for commands
	<b>SKIP DOUBLE</b>	The display windows with double displays are skipped.
	<b>SKIP QUICKSTART</b>	The display window for the quick start of the preselection values is skipped.
	<b>SKIP MIN/MAX</b>	The display window for minimum / maximum values is skipped.

<b>DIAGNOSTIC DISPLAY</b>		
With this parameter, the double display without units can be used as a diagnostic window. When the diagnostic window is activated, the top line corresponds to the current SSI value of the respective encoder rotation and the bottom line corresponds to the entire encoder rotations already recorded.		
<u>Note:</u>		
If the diagnostic window is switched off, the process value set in "SOURCE DUAL TOP" and "SOURCE DUAL DOWN" is also shown on the double display without units.		
	<b>NO</b>	Diagnostic window is switched off
	<b>YES</b>	Diagnostic window is switched on

## 5.14. Linearization Menu

The linearization function is defined in this menu. This menu will only be showed, if the LINEARIZATION MODE in GENERAL MENU is selected.

Linearization description and examples are shown in the appendix.

<b>SOURCE</b>		
This parameter defines the reference source which is to be used for the linearization.		
	<b>0</b>	<b>POSITION</b> Result of the position measurement
	<b>1</b>	<b>SPEED</b> Result of the speed measurement

<b>P1(X) ... P24(X)</b>		
X-coordinate of the linearization point.		
This value representing the display value which the unit show in the display without linearization.		
	<b>-99999999</b>	Smallest X-coordinate
	<b>0</b>	Default value
	<b>+99999999</b>	Largest X-coordinate

<b>P1(Y) ... P24(Y)</b>		
Y-coordinate of the linearization point		
This is the display value, which the unit should show in the display with linearization.		
E.g. P2(X) is replaced by P2(Y).		
	<b>-99999999</b>	Smallest Y-coordinate
	<b>0</b>	Default value
	<b>+99999999</b>	Largest Y-coordinate

# 6. Appendix

## 6.1. Data readout via serial interface

All codes shown in the parameter SERIAL VALUE are available for serial readout by PC or PLC. The communication of the devices is based on the Drivecom protocol according to ISO 1745 or the Modbus RTU protocol. All protocol details can be found in our manual SERPRO (Drivecom) which is available in the chapter "Modbus RTU Interface" in this manual.

**To request for a data transmission you must send the following request string to the converter:**

EOT	AD1	AD2	C1	C2	ENQ
-----	-----	-----	----	----	-----

- EOT = control character (Hex 04)
- AD1 = unit address, High Byte
- AD2 = unit address, Low Byte
- C1 = register code, High Byte
- C2 = register code, Low Byte
- ENQ = control character (Hex 05)

The following example shows the request string for readout of the actual input frequency of a monitor (Code=1) from a unit with unit address 11:

ASCII-Code:	ASCII-Code:	EOT	1	1	:	1	ENQ
Hex-Code:	Hexadecimal:	04	31	31	3A	31	05
Binary-Code:	Binary:	0000 0100	0011 0001	0011 0001	0011 1010	0011 0001	0000 0101

**After a correct request, the unit will respond:**

STX	C1	C2	xxxxx	ETX	BCC
-----	----	----	-------	-----	-----

- STX = control character (Hex 02)
- C1 = register code, High Byte
- C2 = register code, Low Byte
- xxxxx = readout data
- ETX = control character (Hex 03)
- BCC = block check character

## 6.2. Modbus RTU Interface

The Modbus interface of the touchMatrix<sup>®</sup> series is a standard Modbus RTU Slave and provides the following Modbus functions:

- Read Coils
- Write Single Coil
- Read Holding Registers
- Write Multiple Registers
- Diagnosis

For the operation of the interface module and the understanding of this manual basic knowledge in Modbus RTU communication is presupposed.

### 6.2.1. Parameter setting

Required parameter settings in DX350 / DX355 "Serial menu":

#### UNIT NUMMER

Not valid for Modbus communication

(For setting of Modbus address see parameter "MODBUS")

#### SERIAL BAUD RATE

This parameter defines the serial baud rate

<b>0</b>	<b>9600</b>	9600 baud
<b>1</b>	<b>19200</b>	19200 baud
<b>2</b>	<b>38400</b>	38400 baud

#### SERIAL FORMAT

This parameter defines the bit data format.

<b>0</b>	<b>7-EVEN-1</b>	Do not use with Modbus protocol		
<b>1</b>	<b>7-EVEN-2</b>			
<b>2</b>	<b>7-ODD-1</b>			
<b>3</b>	<b>7-ODD-2</b>			
<b>4</b>	<b>7-NONE-1</b>			
<b>5</b>	<b>7-NONE-2</b>			
<b>6</b>	<b>8-EVEN-1</b>	8 data bits	Parity even	1 stop bit
<b>7</b>	<b>8-ODD-1</b>	8 data bits	Parity odd	1 stop bit
<b>8</b>	<b>8-NONE-1</b>	Do not use with Modbus protocol		
<b>9</b>	<b>8-NONE-2</b>	8 data bits	no Parity	2 stop bits

Continuation "Parameter setting":

**SERIAL INIT**

Not valid for Modbus communication

**SERIAL PROTOCOL**

Not valid for Modbus communication

**SERIAL TIMER (S)**

Not valid for Modbus communication

**SERIAL VALUE**

Not valid for Modbus communication

**MODBUS**

This parameter enables the Modbus protocol and determines the Modbus address.

	0	Do not use for Modbus protocol (Modbus disabled)
	1 ... 247	Modbus enabled: Serial interface is using Modbus RTU protocol The number set here determines the Modbus node address.

### 6.2.2. Modbus Communication

The following Modbus functions are available:

#### Read Holding Registers and Write Multiple Registers

With the functions "Read Holding Registers" and "Write Multiple Registers" it is possible to access all registers of the device.

All variables (actual data) and status registers are mapped to Modbus Holding Registers. However, as all registers of the device are 32 bit registers but Modbus Holding registers are only 16 bit registers, each register of the device requires two Holding registers. (For this reason the use of Modbus function "Write Single Register" is not possible.)

It is only possible to access to one single register of the touchMATRIX<sup>®</sup> device by each read or write operation, therefore the "Quantity (or number) of registers" in the Modbus request must always be 2.

#### Access to parameters

Holding Register 0x0000 / 0x0001 hex and following allow access to the device parameters.

The holding register numbers for a certain parameter can be calculated by the parameter # that can be found in the parameter table in the touchMatrix<sup>®</sup> device manual:

Holding Register low = (parameter #) x 2

Holding Register high = (parameter #) x 2 + 1

Example:

Access to parameter # 51 "PRESELECTION 1" by Holding Register 0x0066 and 0x0067 hex.

### Access to actual data

Holding Register 0x1000 / 0x1001 hex and following allow access to variables of the device (actual data registers):

Holding Register 0x1000 / 0x1001 hex → Actual data with serial Code “:0” (Display value)

Holding Register 0x1002 / 0x1003 hex → Actual data with serial Code “:1”

Holding Register 0x1004 / 0x1005 hex → Actual data with serial Code “:2”

Holding Register 0x1006 / 0x1007 hex → Actual data with serial Code “:3”

etc.

### Access to status registers

Holding Register 0x2000 / 0x2001 hex and following allow access to status registers of the device:

Holding Register 0x2000 / 0x2001 hex → Output Status (Ctrl. Out status, read only)

Holding Register 0x2002 / 0x2003 hex → Serial Commands

Holding Register 0x2004 / 0x2005 hex → External Command (Ctrl. In status, read only)

Holding Register 0x2006 / 0x2007 hex → All Commands (read only)

### Read Coils and Write Single Coil

With the functions “Read Coils” and “Write Single Coil” it is possible to read and set/reset single commands:

Coil number	Serial code of command	Command	
0	54	Reset / Set	Reset/Set Value
1	55	Freeze Display	Freeze actual display value
2	56	Touch Disable	Disable touch screen
3	57	Clear Lock	Loosen locking of all outputs / relay
4	58	Clear Min/Max	Reset of the min. / max. values
5	59	Serial Print (do not use with Modbus)	Sending of serial data
6	60	Teach Preset 1	Current display value is stored as PRESELECTION 1
7	61	Teach Preset 2	Current display value is stored as PRESELECTION 2
8	62	Teach Preset 3	Current display value is stored as PRESELECTION 3
9	63	Teach Preset 4	Current display value is stored as PRESELECTION 4
10	64	Scroll Display	Display switching (see display in operation mode)
11	65	Clear Loop Time	Release all latched switching conditions
12	66	Start Preselection	The preselection starts
13	67	Activate Data (not required with Modbus)	The data is activated.
14	68	Store to EEPROM	Store to EEPROM
15	69	Testprogram (do not use with Modbus)	Testprogram (do not use with Modbus)

### 6.2.3. Diagnose

The device supports the diagnostics subfunction 00 "Return Query Data". Other diagnostics functions are not available.

### 6.3. Parameter / serial codes

#	Menu	Name	Serial Code	Min	Max	Default
0	GENERAL MENU	LINEARIZATION MODE	0	0	2	0
1	GENERAL MENU	PIN PRESELECTION	1	0	9999	0
2	GENERAL MENU	PIN PARAMETER	2	0	9999	0
3	GENERAL MENU	FACTORY SETTINGS	3	0	1	0
4	GENERAL MENU	—	4	0	0	0
5	GENERAL MENU	—	5	0	0	0
6	GENERAL MENU	—	6	0	0	0
7	SSI PROPERTIES	MODE	7	0	1	0
8	SSI PROPERTIES	ENCODER RESOLUTION	8	10	32	25
9	SSI PROPERTIES	BIT PER REVOLUTION	9	10	16	13
10	SSI PROPERTIES	DATA FORMAT	10	0	1	0
11	SSI PROPERTIES	BAUD RATE	11	0	5	2
12	SSI PROPERTIES	HIGH BIT	12	1	32	25
13	SSI PROPERTIES	LOW BIT	13	1	32	1
14	SSI PROPERTIES	DIRECTION	14	0	1	0
15	SSI PROPERTIES	ERROR BIT	15	0	32	0
16	SSI PROPERTIES	ERROR POLARITY	16	0	1	0
17	SSI PROPERTIES	ENCODER SUPPLY	17	0	1	1
18	SSI PROPERTIES	—	18	0	0	0
19	SSI PROPERTIES	—	19	0	0	0
20	POSITION SETTINGS	DISPLAY FORMAT	20	0	2	0
21	POSITION SETTINGS	FACTOR	21	-99999999	99999999	1
22	POSITION SETTINGS	DIVIDER	22	-99999999	99999999	1
23	POSITION SETTINGS	ADDITIVE VALUE	23	-99999999	99999999	0
24	POSITION SETTINGS	DECIMAL POINT	24	0	7	0
25	POSITION SETTINGS	SCALE UNIT	25	0	29	0
26	POSITION SETTINGS	SSI OFFSET	26	0	99999999 9	0
27	POSITION SETTINGS	SSI ZERO	27	0	99999999 9	0
28	POSITION SETTINGS	ROUND LOOP VALUE	28	0	99999999	0
29	POSITION SETTINGS	SAMPLING TIME (S)	29	1	9999	10
30	POSITION SETTINGS	—	30	0	0	0
31	POSITION SETTINGS	—	31	0	0	0
32	SPEED SETTINGS	FACTOR	32	-99999999	99999999	1
33	SPEED SETTINGS	DIVIDER	33	-99999999	99999999	1
34	SPEED SETTINGS	DECIMAL POINT	34	0	7	0
35	SPEED SETTINGS	SCALE UNIT	35	0	29	12
36	SPEED SETTINGS	AVERAGE FILTER	36	0	4	0
37	SPEED SETTINGS	SAMPLING TIME (S)	37	1	99	5
38	SPEED SETTINGS	—	38	0	0	0
39	SPEED SETTINGS	—	39	0	0	0
40	PRESELECTION VALUES	PRESELECTION 1	A0	-99999999	99999999	1000
41	PRESELECTION VALUES	PRESELECTION 2	A1	-99999999	99999999	2000
42	PRESELECTION VALUES	PRESELECTION 3	A2	-99999999	99999999	3000

43	PRESELECTION VALUES	PRESELECTION 4	A3	-99999999	99999999	4000
----	---------------------	----------------	----	-----------	----------	------

Continuation „Parameterliste“:

#	Menu	Name	Serial Code	Min	Max	Default
44	PRESELECTION 1 MENU	SOURCE 1	A4	0	1	0
45	PRESELECTION 1 MENU	MODE 1	A5	0	7	0
46	PRESELECTION 1 MENU	HYSTERESIS 1	A6	0	99999	0
47	PRESELECTION 1 MENU	PULSE TIME 1 (S)	A7	0	60000	0
48	PRESELECTION 1 MENU	OUTPUT TARGET 1	A8	0	6	1
49	PRESELECTION 1 MENU	OUTPUT POLARITY 1	A9	0	1	0
50	PRESELECTION 1 MENU	OUTPUT LOCK 1	B0	0	1	0
51	PRESELECTION 1 MENU	START UP DELAY 1 (S)	B1	0	60000	0
52	PRESELECTION 1 MENU	EVENT COLOR 1	B2	0	3	0
53	PRESELECTION 1 MENU	___	B3	0	0	0
54	PRESELECTION 2 MENU	SOURCE 2	B4	0	1	0
55	PRESELECTION 2 MENU	MODE 2	B5	0	7	0
56	PRESELECTION 2 MENU	HYSTERESIS 2	B6	0	99999	0
57	PRESELECTION 2 MENU	PULSE TIME 2 (S)	B7	0	60000	0
58	PRESELECTION 2 MENU	OUTPUT TARGET 2	B8	0	6	2
59	PRESELECTION 2 MENU	OUTPUT POLARITY 2	B9	0	1	0
60	PRESELECTION 2 MENU	OUTPUT LOCK 2	C0	0	1	0
61	PRESELECTION 2 MENU	START UP DELAY 2 (S)	C1	0	60000	0
62	PRESELECTION 2 MENU	EVENT COLOR 2	C2	0	3	0
63	PRESELECTION 2 MENU	___	C3	0	0	0
64	PRESELECTION 3 MENU	SOURCE 3	C4	0	1	0
65	PRESELECTION 3 MENU	MODE 3	C5	0	7	0
66	PRESELECTION 3 MENU	HYSTERESIS 3	C6	0	99999	0

67	PRESELECTION 3 MENU	PULSE TIME 3 (S)	C7	0	60000	0
68	PRESELECTION 3 MENU	OUTPUT TARGET 3	C8	0	6	3
69	PRESELECTION 3 MENU	OUTPUT POLARITY 3	C9	0	1	0
70	PRESELECTION 3 MENU	OUTPUT LOCK 3	D0	0	1	0
71	PRESELECTION 3 MENU	START UP DELAY 3	D1	0	1	0
72	PRESELECTION 3 MENU	EVENT COLOR 3	D2	0	3	0
73	PRESELECTION 3 MENU	___	D3	0	0	0
74	PRESELECTION 4 MENU	SOURCE 4	D4	0	1	0
75	PRESELECTION 4 MENU	MODE 4	D5	0	7	0
76	PRESELECTION 4 MENU	HYSTERESIS 4	D6	0	99999	0
77	PRESELECTION 4 MENU	PULSE TIME 4 (S)	D7	0	60000	0
78	PRESELECTION 4 MENU	OUTPUT TARGET 4	D8	0	6	4
79	PRESELECTION 4 MENU	OUTPUT POLARITY 4	D9	0	1	0
80	PRESELECTION 4 MENU	OUTPUT LOCK 4	E0	0	1	0
81	PRESELECTION 4 MENU	START UP DELAY 4	E1	0	1	0
82	PRESELECTION 4 MENU	EVENT COLOR 4	E2	0	3	0
83	PRESELECTION 4 MENU	___	E3	0	0	0
84	SERIAL MENU	UNIT NUMBER	90	11	99	11
85	SERIAL MENU	SERIAL BAUD RATE	91	0	2	0
86	SERIAL MENU	SERIAL FORMAT	92	0	9	0
87	SERIAL MENU	SERIAL INIT	9~	0	1	0
88	SERIAL MENU	SERIAL PROTOCOL	E4	0	1	0

Continuation „Parameterliste“:

#	Menu	Name	Serial Code	Min	Max	Default
89	SERIAL MENU	SERIAL TIMER (S)	E5	0	60000	0
90	SERIAL MENU	SERIAL VALUE	E6	0	9	0
91	SERIAL MENU	MODBUS	E7	0	247	0
92	ANALOG MENU	ANALOG SOURCE	E8	0	1	0
93	ANALOG MENU	ANALOG FORMAT	E9	0	2	0
94	ANALOG MENU	ANALOG START	F0	-99999999	99999999	0
95	ANALOG MENU	ANALOG END	F1	-99999999	99999999	10000
96	ANALOG MENU	ANALOG GAIN %	F2	0	11000	10000
97	ANALOG MENU	ANALOG OFFSET %	F3	-9999	9999	0
98	ANALOG MENU	—	F4	0	0	0
99	COMMAND MENU	INPUT 1 ACTION	F5	0	22	0
100	COMMAND MENU	INPUT 1 CONFIG.	F6	0	3	2
101	COMMAND MENU	INPUT 2 ACTION	F7	0	22	0
102	COMMAND MENU	INPUT 2 CONFIG.	F8	0	3	2
103	COMMAND MENU	INPUT 3 ACTION	F9	0	22	0
104	COMMAND MENU	INPUT 3 CONFIG.	G0	0	3	2
105	COMMAND MENU	—	G1	0	0	0
106	COMMAND MENU	—	G2	0	0	0
107	COMMAND MENU	—	G3	0	0	0
108	COMMAND MENU	—	G4	0	0	0
109	COMMAND MENU	—	G5	0	0	0
110	DISPLAY MENU	SOURCE SINGLE	G6	0	1	0
111	DISPLAY MENU	SOURCE DUAL TOP	G7	0	1	0
112	DISPLAY MENU	SOURCE DUAL DOWN	G8	0	1	1
113	DISPLAY MENU	LARGE DISPLAY	G9	0	5	0
114	DISPLAY MENU	START DISPLAY	H0	0	6	0
115	DISPLAY MENU	COLOR	H1	0	2	0
116	DISPLAY MENU	BRIGHTNESS %	H2	10	100	90
117	DISPLAY MENU	CONTRAST	H3	0	2	1
118	DISPLAY MENU	SCREEN SAVER (S)	H4	0	9999	0
119	DISPLAY MENU	UP-DATE-TIME (S)	H5	5	9999	100
120	DISPLAY MENU	FONT	H6	0	1	0
121	DISPLAY MENU	SKIP WINDOW	H7	0	4	0
122	DISPLAY MENU	DIAGNOSTIC DISPLAY	H8	0	1	1
123	DISPLAY MENU	—	H9	0	0	0
124	LINEARIZATION MENU	SOURCE	I0	0	1	0
125	LINEARIZATION MENU	P1(X)	I1	-99999999	99999999	0
126	LINEARIZATION MENU	P1(Y)	I2	-99999999	99999999	0
127	LINEARIZATION MENU	P2(X)	I3	-99999999	99999999	0
128	LINEARIZATION MENU	P2(Y)	I4	-99999999	99999999	0
129	LINEARIZATION MENU	P3(X)	I5	-99999999	99999999	0
130	LINEARIZATION MENU	P3(Y)	I6	-99999999	99999999	0
131	LINEARIZATION MENU	P4(X)	I7	-99999999	99999999	0
132	LINEARIZATION MENU	P4(Y)	I8	-99999999	99999999	0
133	LINEARIZATION MENU	P5(X)	I9	-99999999	99999999	0
134	LINEARIZATION MENU	P5(Y)	J0	-99999999	99999999	0
135	LINEARIZATION MENU	P6(X)	J1	-99999999	99999999	0
136	LINEARIZATION MENU	P6(Y)	J2	-99999999	99999999	0



#	Menu	Name	Serial Code	Min	Max	Default
137	LINEARIZATION MENU	P7(X)	J3	-99999999	99999999	0
138	LINEARIZATION MENU	P7(Y)	J4	-99999999	99999999	0
139	LINEARIZATION MENU	P8(X)	J5	-99999999	99999999	0
140	LINEARIZATION MENU	P8(Y)	J6	-99999999	99999999	0
141	LINEARIZATION MENU	P9(X)	J7	-99999999	99999999	0
142	LINEARIZATION MENU	P9(Y)	J8	-99999999	99999999	0
143	LINEARIZATION MENU	P10(X)	J9	-99999999	99999999	0
144	LINEARIZATION MENU	P10(Y)	K0	-99999999	99999999	0
145	LINEARIZATION MENU	P11(X)	K1	-99999999	99999999	0
146	LINEARIZATION MENU	P11(Y)	K2	-99999999	99999999	0
147	LINEARIZATION MENU	P12(X)	K3	-99999999	99999999	0
148	LINEARIZATION MENU	P12(Y)	K4	-99999999	99999999	0
149	LINEARIZATION MENU	P13(X)	K5	-99999999	99999999	0
150	LINEARIZATION MENU	P13(Y)	K6	-99999999	99999999	0
151	LINEARIZATION MENU	P14(X)	K7	-99999999	99999999	0
152	LINEARIZATION MENU	P14(Y)	K8	-99999999	99999999	0
153	LINEARIZATION MENU	P15(X)	K9	-99999999	99999999	0
154	LINEARIZATION MENU	P15(Y)	L0	-99999999	99999999	0
155	LINEARIZATION MENU	P16(X)	L1	-99999999	99999999	0
156	LINEARIZATION MENU	P16(Y)	L2	-99999999	99999999	0
157	LINEARIZATION MENU	P17(X)	L3	-99999999	99999999	0
158	LINEARIZATION MENU	P17(Y)	L4	-99999999	99999999	0
159	LINEARIZATION MENU	P18(X)	L5	-99999999	99999999	0
160	LINEARIZATION MENU	P18(Y)	L6	-99999999	99999999	0
161	LINEARIZATION MENU	P19(X)	L7	-99999999	99999999	0
162	LINEARIZATION MENU	P19(Y)	L8	-99999999	99999999	0
163	LINEARIZATION MENU	P20(X)	L9	-99999999	99999999	0
164	LINEARIZATION MENU	P20(Y)	M0	-99999999	99999999	0
165	LINEARIZATION MENU	P21(X)	M1	-99999999	99999999	0
166	LINEARIZATION MENU	P21(Y)	M2	-99999999	99999999	0
167	LINEARIZATION MENU	P22(X)	M3	-99999999	99999999	0
168	LINEARIZATION MENU	P22(Y)	M4	-99999999	99999999	0
169	LINEARIZATION MENU	P23(X)	M5	-99999999	99999999	0
170	LINEARIZATION MENU	P23(Y)	M6	-99999999	99999999	0
171	LINEARIZATION MENU	P24(X)	M7	-99999999	99999999	0
172	LINEARIZATION MENU	P24(Y)	M8	-99999999	99999999	0

## Serial codes of commands:

Serial Code	Command
54	RESET/SET
55	FREEZE DISPLAY
56	TOUCH DISABLE
57	CLR LOCK
58	CLR MIN MAX
59	SERIAL PRINT
60	TEACH PRES 1
61	TEACH PRES 2
62	TEACH PRES 3
63	TEACH PRES 4
64	SCROLL_DISPLAY

65	CLEAR LOOP TIME
66	START PRESELCTION
67	ACTIVATE DATA
68	STORE EEPROM
69	TESTPROGRAMM

## 6.4. Linearization

The linearization function of this unit allows converting a linear input signal into a non-linear developing (or vice versa). There are 24 programmable x/y coordinates available, which can be set in any desired distance over the full conversion range. Between two coordinates, the unit uses linear interpolation. Therefore it is advisable to use more coordinates in a range with strong curves and only a few coordinates where the curvature is less.

<sup>5.</sup> To specify an individual linearization curve, the parameter LINEARISAZATION MODE must be set to either 1 QUADRANT or 4 QUADRANT (see following diagram).

<sup>6.</sup> The parameters P1(X) to P24(X) are used to specify the coordinates on the x-axis. These are the measuring values that the unit normally would generate according to the actual input signal.

<sup>7.</sup> Now enter the attached values to parameter P1(Y) to P24(Y). These are the values that the unit will generate instead of the x- values, i.e. P5(Y) replaces P5(X) etc.

**The X-Coordinates must use continuously increasing settings, i.e. P1(X) must have the lowest and P24(X) must have the highest setting. If the measured value is bigger than the last defined X-value, the corresponding Y-value is displayed.**

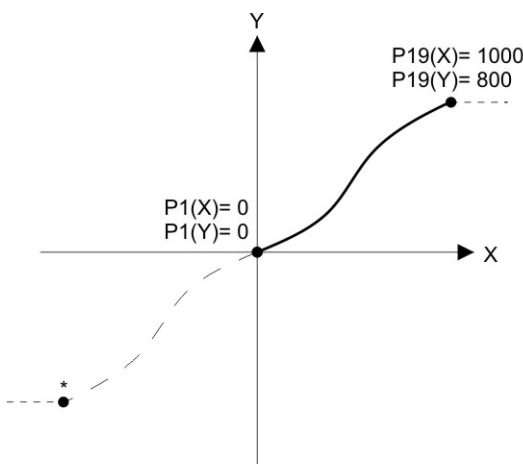

Example: Linearization Mode: 1 Quadrant

\* Linearization is point symmetric to 1. Quadrant

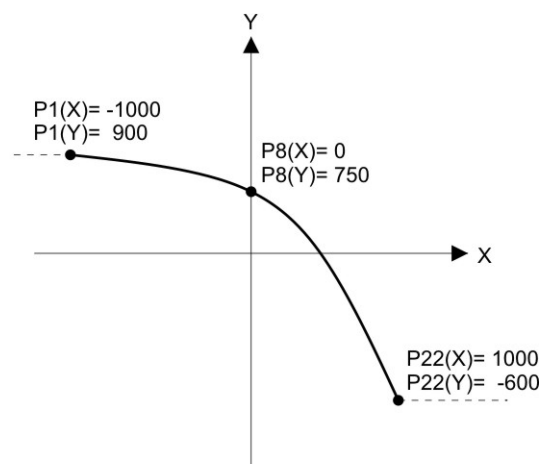

Example: Linearization Mode: 4 Quadrant

### **Mode: 1 Quadrant:**

**P1(X) must be set to zero. Linearization is only defined in the positive range and the negative range will be mirrored symmetric to central point.**

### **Mode: 4 Quadrant:**

**P1(X) can also be set to a negative value. If the measured value is smaller than P1(X), P1(Y) is displayed.**

Application Example:

The picture below shows a watergate where the opening is picked up by means of an incremental encoder. We would like to display the clearance of the gate "d", but the existing encoder information is proportional to the angular information  $\varphi$ .

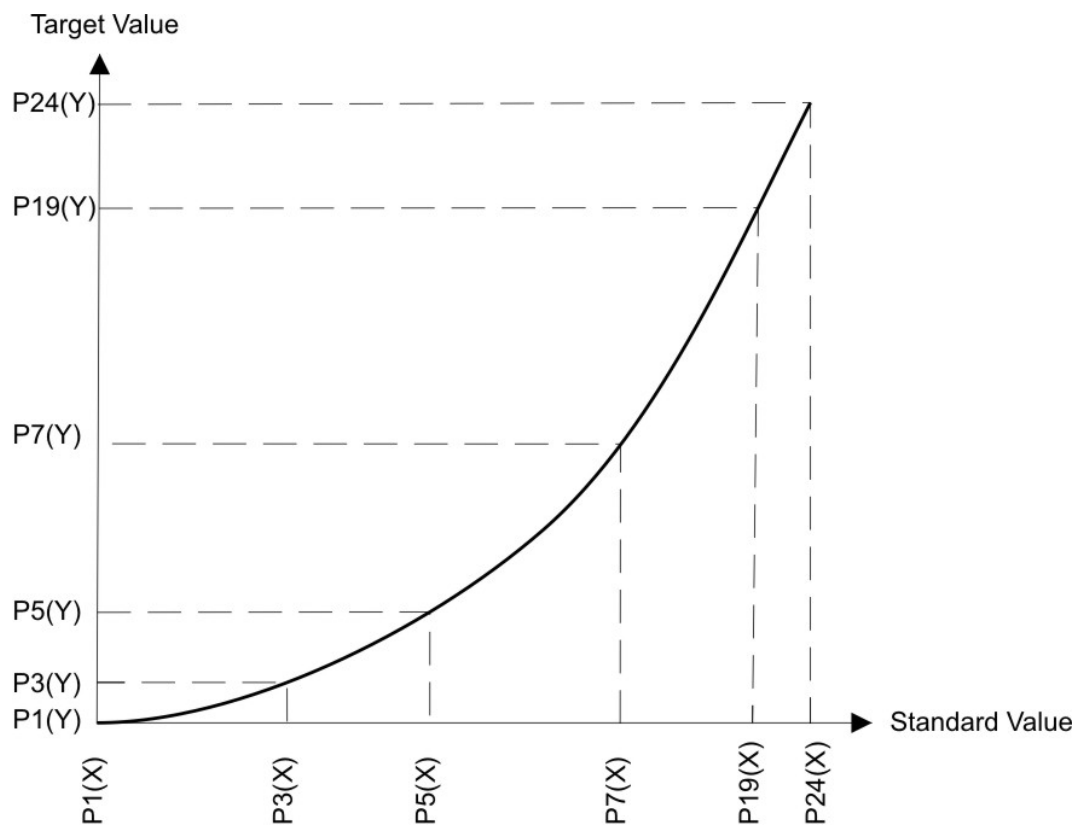
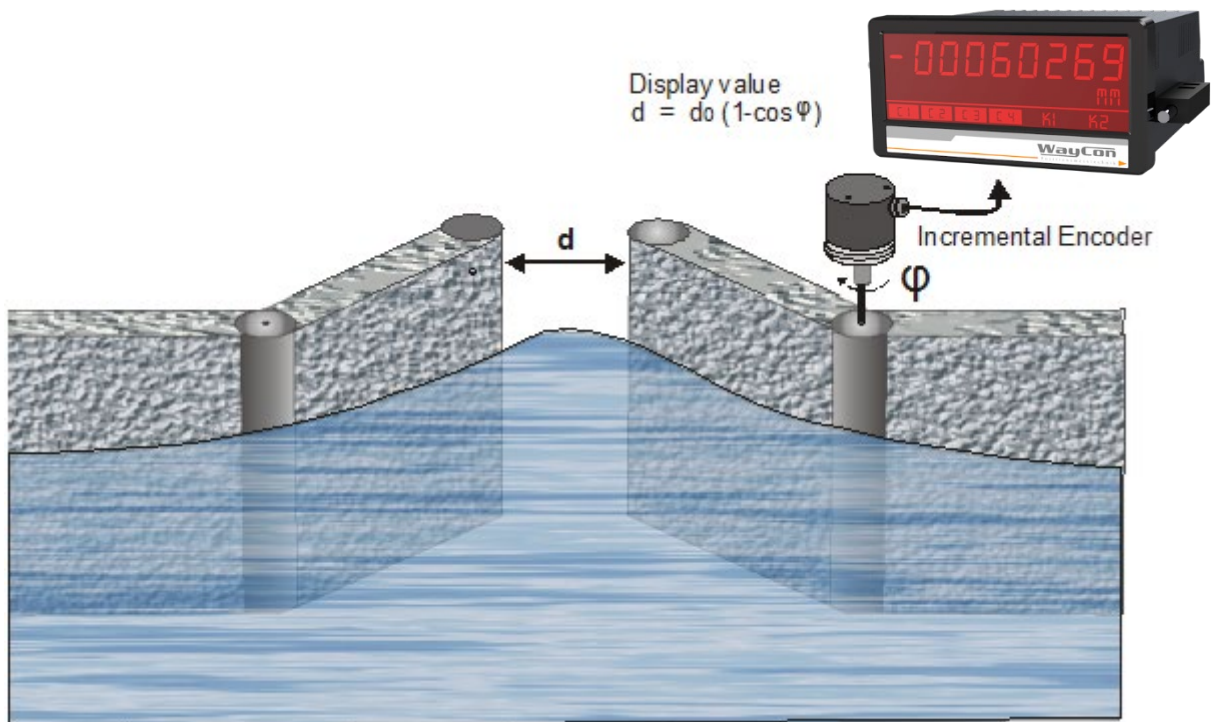

## 6.5. Reading SSI-Value

The received data is always filled to 32 bit data length.

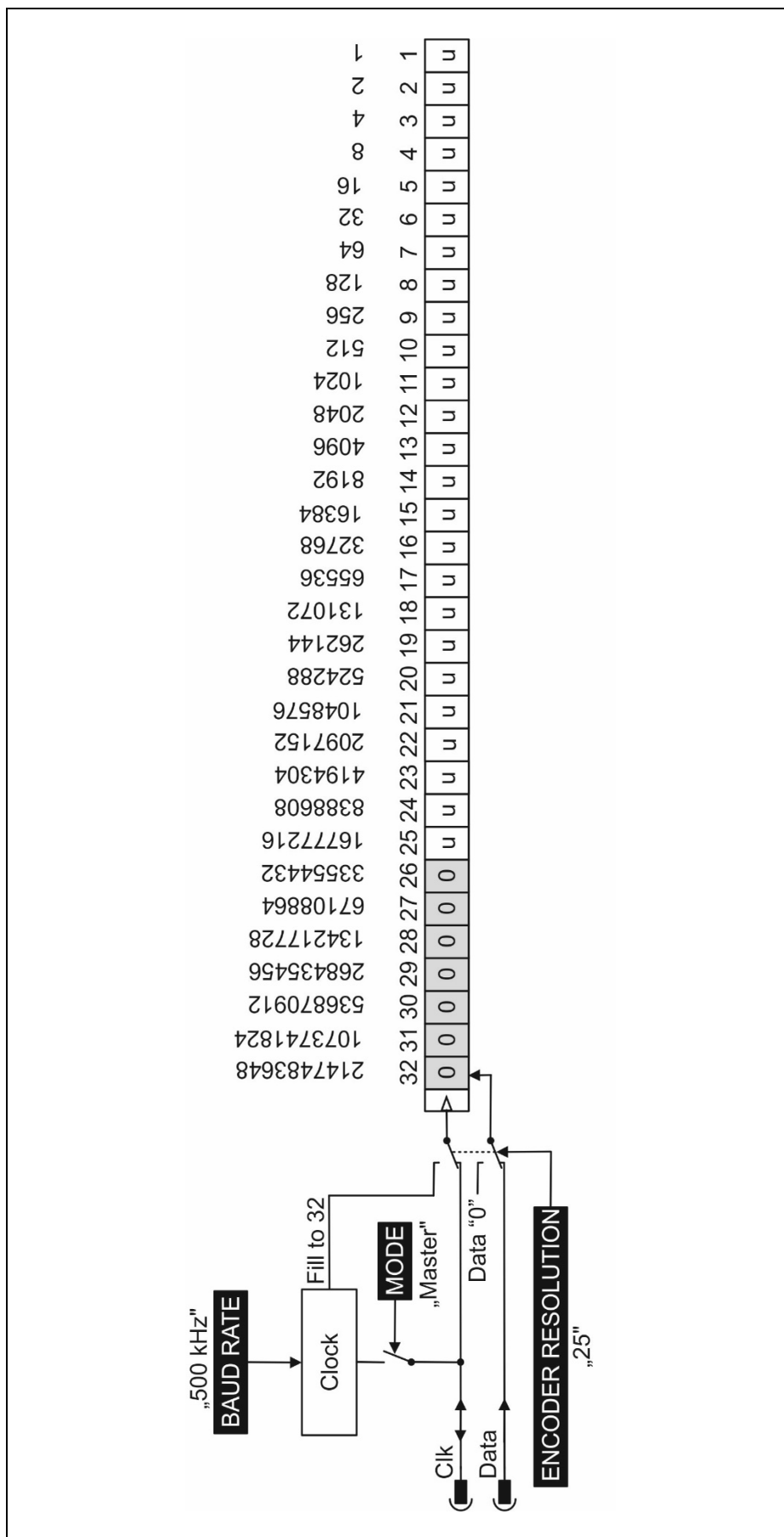

## 6.6. Internal processing and calculation of SSI data

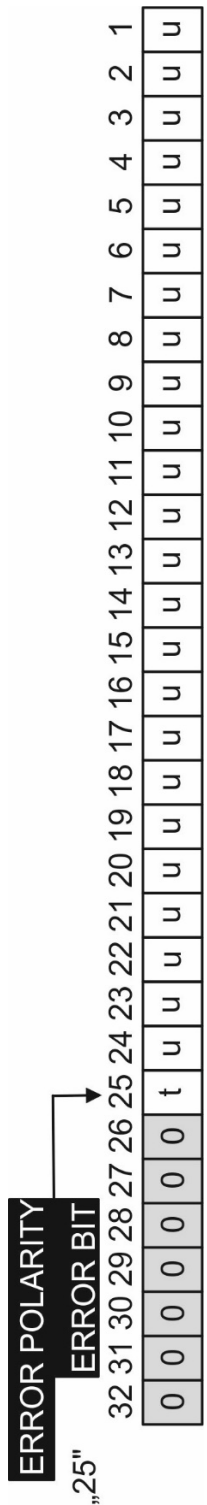
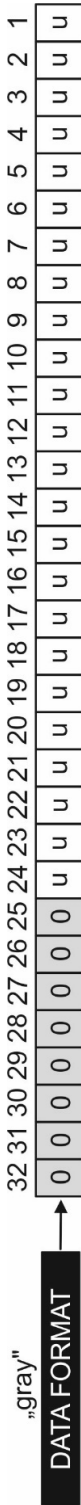
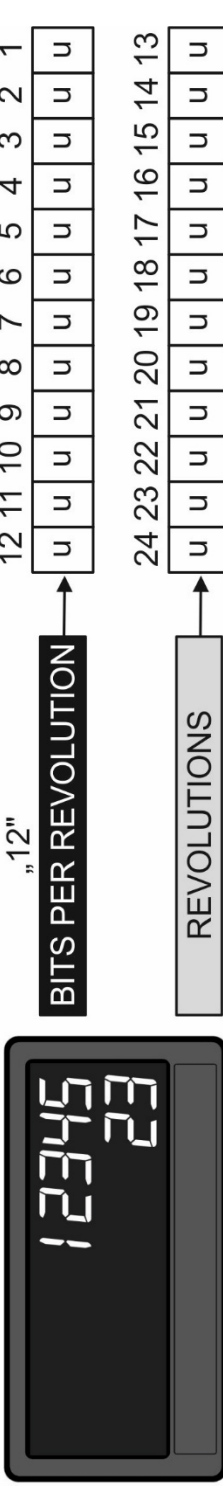
<p>Checking the error bit:</p>	
<p>Data Conversion: Gray Code → binary</p>	
<p>Data splitting: Bit per revolution and number of revolutions</p>	

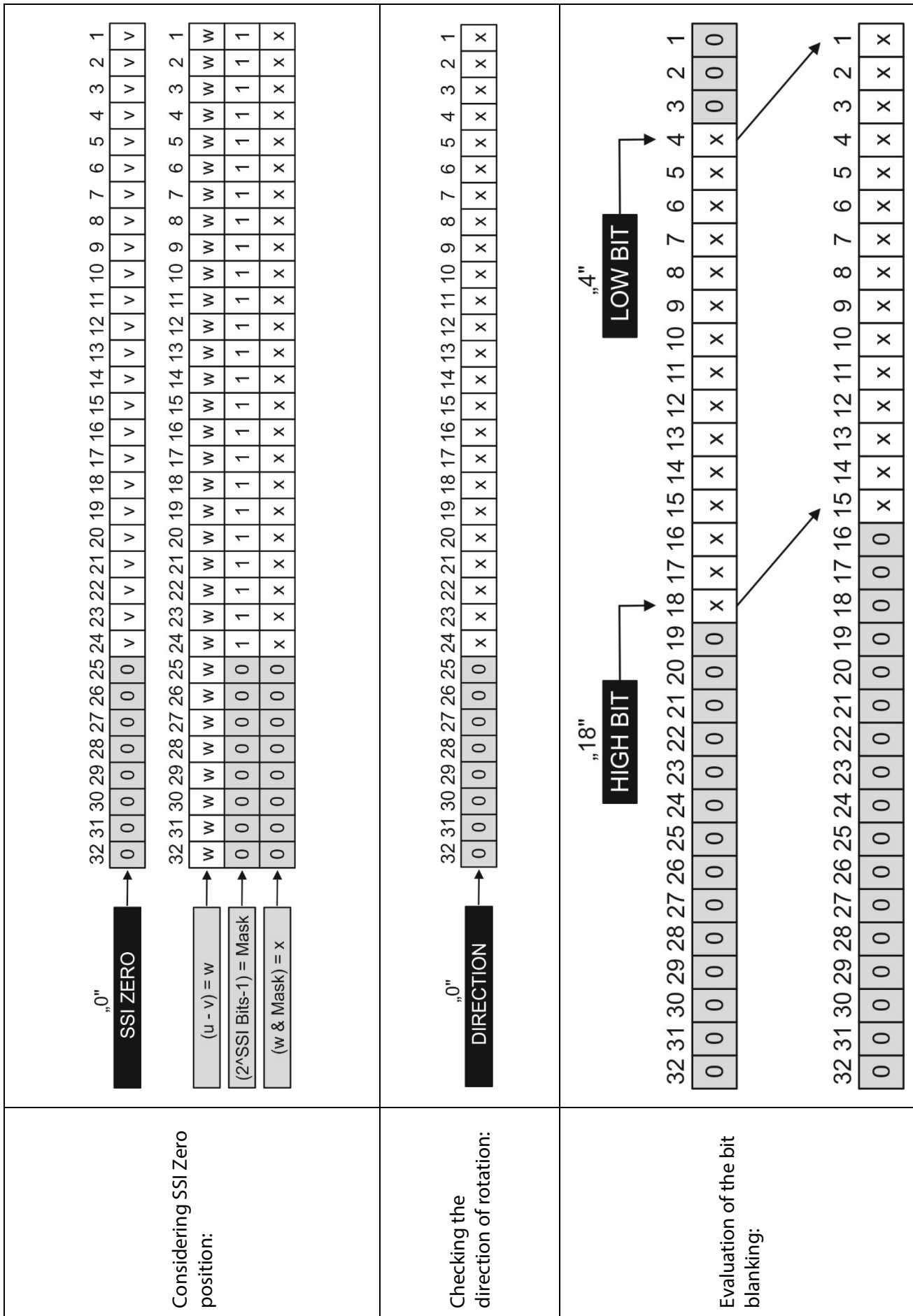

<p>Considering SSI Offset:</p>	<div style="display: flex; flex-direction: column; align-items: center;"> <div style="display: flex; align-items: center; margin-bottom: 10px;"> <div style="border: 1px solid black; padding: 2px 5px; margin-right: 5px;">"0"</div> <div style="border: 1px solid black; padding: 2px 5px; margin-right: 5px;">SSI OFFSET</div> <div style="margin-left: 10px;">↑</div> </div> <table border="1" style="border-collapse: collapse; text-align: center; width: 100%;"> <tr> <td>32</td><td>31</td><td>30</td><td>29</td><td>28</td><td>27</td><td>26</td><td>25</td><td>24</td><td>23</td><td>22</td><td>21</td><td>20</td><td>19</td><td>18</td><td>17</td><td>16</td><td>15</td><td>14</td><td>13</td><td>12</td><td>11</td><td>10</td><td>9</td><td>8</td><td>7</td><td>6</td><td>5</td><td>4</td><td>3</td><td>2</td><td>1</td> </tr> <tr> <td>0</td><td>0</td><td>0</td><td>0</td><td>0</td><td>0</td><td>0</td><td>0</td><td>0</td><td>0</td><td>0</td><td>0</td><td>0</td><td>0</td><td>0</td><td>0</td><td>0</td><td>0</td><td>0</td><td>0</td><td>0</td><td>0</td><td>0</td><td>0</td><td>0</td><td>0</td><td>0</td><td>0</td><td>0</td><td>0</td><td>0</td><td>0</td><td>0</td><td>0</td><td>0</td> </tr> </table>   <table border="1" style="border-collapse: collapse; text-align: center; width: 100%;"> <tr> <td>32</td><td>31</td><td>30</td><td>29</td><td>28</td><td>27</td><td>26</td><td>25</td><td>24</td><td>23</td><td>22</td><td>21</td><td>20</td><td>19</td><td>18</td><td>17</td><td>16</td><td>15</td><td>14</td><td>13</td><td>12</td><td>11</td><td>10</td><td>9</td><td>8</td><td>7</td><td>6</td><td>5</td><td>4</td><td>3</td><td>2</td><td>1</td> </tr> <tr> <td>z</td><td>z</td><td>z</td><td>z</td><td>z</td><td>z</td><td>z</td><td>z</td><td>z</td><td>z</td><td>z</td><td>z</td><td>z</td><td>z</td><td>z</td><td>z</td><td>z</td><td>z</td><td>z</td><td>z</td><td>z</td><td>z</td><td>z</td><td>z</td><td>z</td><td>z</td><td>z</td><td>z</td><td>z</td><td>z</td><td>z</td><td>z</td><td>z</td><td>z</td> </tr> </table> <div style="margin-top: 10px;"> <div style="border: 1px solid black; padding: 2px 5px; margin-right: 5px;">(x - y) = z</div> <div style="margin-left: 10px;">↑</div> </div> </div>	32	31	30	29	28	27	26	25	24	23	22	21	20	19	18	17	16	15	14	13	12	11	10	9	8	7	6	5	4	3	2	1	0	0	0	0	0	0	0	0	0	0	0	0	0	0	0	0	0	0	0	0	0	0	0	0	0	0	0	0	0	0	0	0	0	0	0	32	31	30	29	28	27	26	25	24	23	22	21	20	19	18	17	16	15	14	13	12	11	10	9	8	7	6	5	4	3	2	1	z	z	z	z	z	z	z	z	z	z	z	z	z	z	z	z	z	z	z	z	z	z	z	z	z	z	z	z	z	z	z	z	z	z
32	31	30	29	28	27	26	25	24	23	22	21	20	19	18	17	16	15	14	13	12	11	10	9	8	7	6	5	4	3	2	1																																																																																																							
0	0	0	0	0	0	0	0	0	0	0	0	0	0	0	0	0	0	0	0	0	0	0	0	0	0	0	0	0	0	0	0	0	0	0																																																																																																				
32	31	30	29	28	27	26	25	24	23	22	21	20	19	18	17	16	15	14	13	12	11	10	9	8	7	6	5	4	3	2	1																																																																																																							
z	z	z	z	z	z	z	z	z	z	z	z	z	z	z	z	z	z	z	z	z	z	z	z	z	z	z	z	z	z	z	z	z	z																																																																																																					
<p>Calculation Display Value:</p>	<div style="display: flex; flex-direction: column; align-items: center;">    <math display="block">= \left( \frac{z}{\text{DIVIDER}^{\text{"1"}}} \times \text{FACTOR}^{\text{"1"}} \right) + \text{ADDITIVE VALUE}^{\text{"0"}}</math> </div>																																																																																																																																					

## 6.7. Dimensions

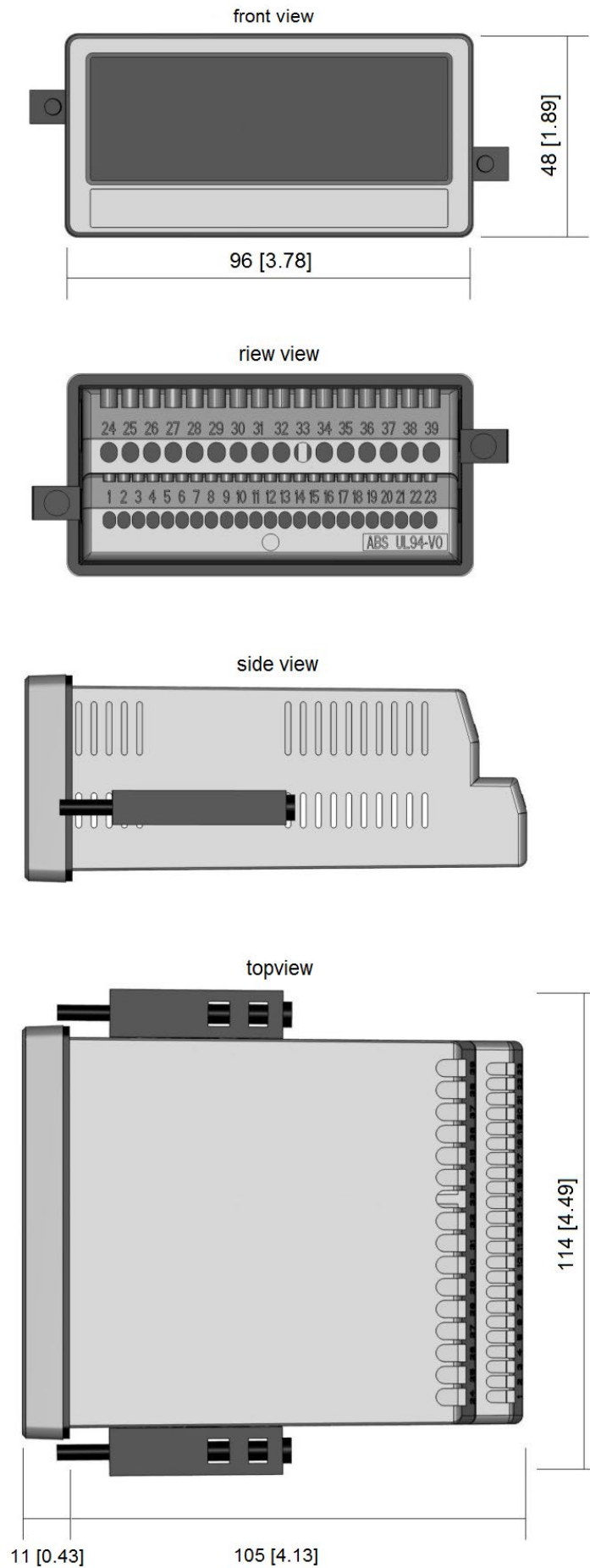



## 6.8. Technical Specifications:

Technical Specifications:		
<b>Connections:</b>	Connector type:	screw terminal, 1.5 mm <sup>2</sup> / AWG 16
<b>Power supply (DC):</b>	Input voltage:	18 ... 30 VDC
	Protection circuit:	reverse polarity protection
	Consumption:	approx. 150 mA (unloaded)
	Fuse protection:	extern: T 0.5 A
<b>Power supply (AC):</b> (Option AC)	Input voltage:	115 / 230 VAC (60/50 Hz)
	Power consumption:	approx. 5 VA (unloaded)
	Fuse protection:	extern: T 0.1 A
<b>Encoder supply:</b>	DC version:	24 VDC (approx. 1 V lower than the power supply voltage), max 250 mA or 5 VDC ( $\pm 15\%$ ), max. 250 mA
	AC version	24 VDC ( $\pm 15\%$ ) (max 150 mA until 45°C / 80 mA by more than 45°C) or 5 VDC ( $\pm 15\%$ ), max. 250 mA)
<b>SSI interface:</b>	Number (channels):	1 (Clock, /Clock, Data, /Data)
	Configuration:	Master or Slave
	Format:	Binary or Gray code
	Frequency:	Max. 1 MHz
	Resolution:	10 ... 32 Bit
	Load:	Max. 2 mA / $R_i > 10 \text{ k}\Omega$ / 47 pF
<b>Control inputs:</b>	Number of inputs:	3
	Format:	HTL, PNP (10 ... 30 V)
	Frequency:	Max. 10 kHz
	Load:	Max. 2 mA / $R_i > 15 \text{ k}\Omega$ / 470 pF
<b>Analog output:</b> (Option AO/AR)	Configuration:	current or voltage operation
	Voltage output:	-10...+10 V (Low 0 ...3 V, High 9 ...30 V)
	Current output:	0/4 ... 20 mA (burden: max. 270 Ohm)
	Resolution:	16 Bit
	Accuracy:	$\pm 0,1 \%$ 0°C ... +45°C $\pm 0,15 \%$ -20°C ... 0°C und +45°C ... +60°C
Reaction time:	< 150 ms	
<b>Control outputs:</b> (Option AO/AR/CO/CR)	Number of outputs:	4
	Format / level:	5 ... 30 V (depends on the Com+ voltage), PNP
	Output current:	Max. 200 mA
	Reaction time:	< 1 ms
<b>Relay outputs:</b> (Option RL)	Number of outputs:	2
	Configuration:	potential free changeovers
	AC-Switching capacity:	Max. 250 VAC / 3 A / 750 VA
	DC-Switching capacity:	Max. 150 VDC / 2 A / 50 W
	Reaction time:	< 20 ms

Continuation "Technical Specifications":

<b>Serial interface:</b> (Option AO/AR/CO/CR)	Format (Option A0/CO): Format (Option AR/CR) Baudrate:	RS232 RS485 9600, 19200 or 38400 baud
<b>Display:</b>	Type: Display range: Digit height Color: Operation:	LCD (backlight) 8 digits plus sign (-99999999 ... 999999999) 13 mm height red / green / yellow (switchable) resistive touchscreen
<b>Housing:</b>	Material: Mounting: Dimensions (w x h x d): Cut out (w x h): Protection class: Weight:	ABS, UL 94 V-0 panel cut out 96 x 48 x 116 mm / 3.78 x 1.89 x 4,56 inch 91 x 44 mm / 3.58 x 1.69 inch IP65 (front), IP20 (rear) approx. 200 g
<b>Ambient temperature:</b>	Operation: Storage:	-20 °C ... +60 °C resp. -4 ... 140 °F -25 °C ... +70 °C resp. -13 ... 158 °F
<b>Conformity and standards:</b>	EMC 2014/30/EU:  LV 2014/35/EU: (Only for option AC and RL) RoHS ( II ) 2011/65/EU RoHS (III) 2015/863:	EN 61326-1 for industrial location EN 55011 / CISPR11 Class A EN 61010-1   EN IEC 63000